



# RS-50 Skid Steer Loader



## RS-50 Brief Specifications

Operating weight:	6,065 lbs   2751 kg
Tipping load:	3,300 lbs   1497 kg
Breakout force:	4,750 lbs   2154 kg
Gross engine power:	50 hp   37.3 kW

## OPERATING SPECIFICATIONS

Loader arms	Radial
Operating weight	6,065 lbs   2751 kg
Shipping weight	5,331 lbs   2418 kg
Operating capacity, 50% of tipping load	1,650 lbs   748 kg
Tipping load	3,300 lbs   1497 kg
Travel speed, maximum - 1 <sup>st</sup> speed	7.4 mph   11.9 kph
Travel speed, maximum - 2 <sup>nd</sup> Speed (optional)	12 mph   19.3 kph
Breakout force at bucket edge	4,750 lbs   2154 kg
Arm lifting force	4,750 lbs   2154 kg
Ground clearance, unloaded	10.5 in.   267 mm
Ground clearance, loaded	10 in.   254 mm
Width over tires	66 in.   1676 mm
Width over tires with rims reversed	60 in.   1524 mm

## ENGINE

Type	Diesel, 4-cylinder, naturally-aspirated
Model	Perkins 404D-22
Displacement	135 in <sup>3</sup>   2.2 L
Gross power rating @ 2800 rpm	50 hp   37.3 kW
Torque, peak	105 ft-lb   143 Nm
Cooling system	Engine-driven fan and coolant/ anti-freeze-filled radiator
Intake air cleaner	Dual stage
Emission controls	Meets all U.S. EPA Tier 4 final standards

## DRIVE TRAIN

Drive system	Hydrostatic
Chain case	Bow tie drive system
Chain size	80 ANSI chain
Wheel size	10x16.5
Tractive effort	8,453 lbs   3826 kg

\* Machine tested with foundry bucket

## AUX. HYDRAULIC SYSTEM

Pump capacity	17.1 gpm   65 lpm
System pressure, max.	3,335 psi   230 bar
Controls	Intermittent via joystick button or continuous via console switch, mode selectable via dash-mounted switch
Couplers	Push-to-connect quick couplers mounted on loader arms Pressure relief valve mounted to coupler block
Cooling system	High efficiency side-by-side radiator and oil cooler

## ELECTRICAL SYSTEM

Nominal charge	12 V
Battery	770 CCA
Charging system	65 amp alternator
Outlets	1-12 V port inside operator station
Engine Block Heater	Standard
Wiring	Pre-wired for all factory-available accessories

## OPERATOR STATION

Seat:	Adjustable contour vinyl with built-in operator presence switch, lap bar and 2 in   51 mm wide seat belt
Loader control:	Right-hand pilot hydraulic joystick controls loader lift, lower and tilt, plus intermittent control of auxiliary hydraulic
Drive control:	Left-hand pilot hydraulic joystick controls machine speed and direction
Engine speed	Foot throttle
Indicators & gauges	Engine oil low-pressure light Hydraulic oil high-temperature light Engine high-temperature light Low battery voltage light Tachometer, hour meter, fuel gauge Two speed
ROPS / FOPS	Meets ISO 3471, ISO 6683, ISO 3449:2005 Level 1
Illumination	2 - Fixed forward-facing halogen lights 2 - Adjustable rear-facing halogen light 1 - Interior light
Convenience	12 V power port
Horn	
Backup alarm	
Sound insulation	
Rear window	

# DIMENSIONS

# RS-50

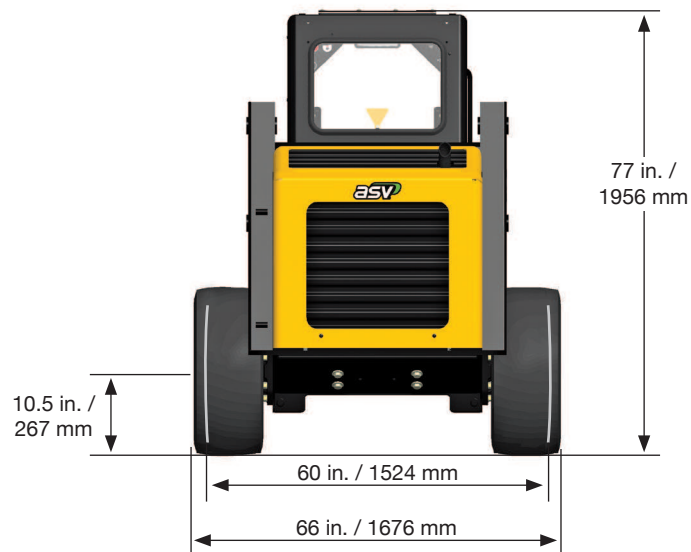
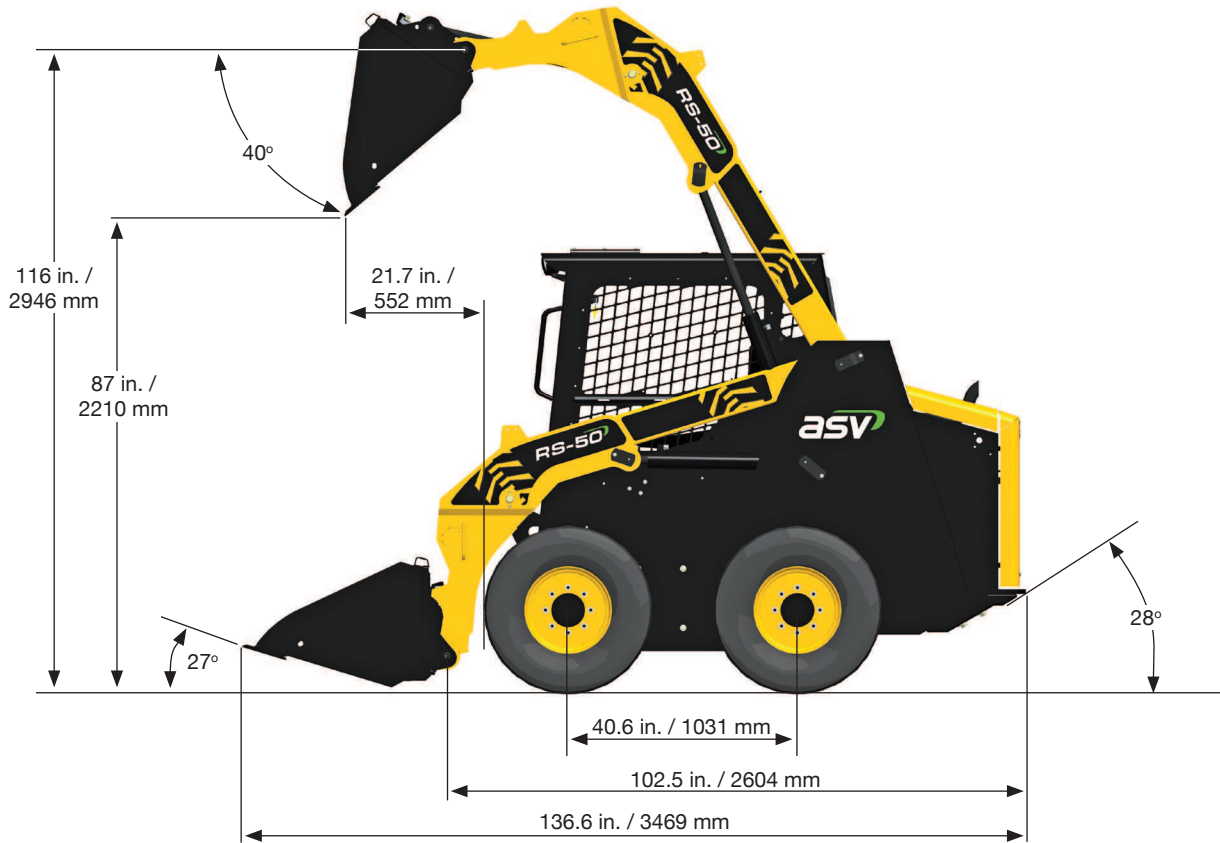

## SERVICE REFILL CAPACITIES

Fuel tank	25 gal   95 L
Hydraulic tank	8 gal   30 L
Engine coolant/antifreeze	3.5 gal   13 L
Engine oil, including filter	11.2 quarts   10.6 L

## OPTIONAL ATTACHMENTS

Auger drive and bits	Grapple bucket
Backhoe	Pallet forks
Broom, rotary	Power box rake
Bucket, general purpose	Snow blade
Bucket, light material	Snow blower
Bucket, multi-purpose	Stump grinder
Brush cutter, rotary	Trencher
Dozer blade	Vibratory roller
Eliminator rake	

Effective Date: September, 2016

Product specifications and prices are subject to change without notice or obligation. The photographs and/or drawings in this document are for illustrative purposes only. Refer to the appropriate Operator's Manual for instructions on the proper use of this equipment. Failure to follow the appropriate Operator's Manual when using our equipment or to otherwise act irresponsibly may result in serious injury or death. The only warranty applicable to our equipment is the standard written warranty applicable to the particular product and sale and ASV makes no other warranty, express or implied. © 2016, ASV LLC. ASV, the ASV logo design and Positrack are trademarks of ASV, LLC.