

# Mine dump truck BELAZ-75450 of payload capacity 45 tonnes

It's designed for transportation of rock mass in difficult mining and technical conditions of deep mines, at mineral deposit open pits on technological roads under various climatic operating conditions (at ambient temperature from -50 to +50 °C).



<b>Engine</b>	
Model	CUMMINS QSX-15
Four-cycle gas-turbocharged and intercooled direct diesel engine with in-line cylinders arrangement and electronic control system. The engine meets Tier3 (Stage 3A) toxic substances emission requirements.	
Rated power @ 2100 rpm, kW (hp)	448(600)
Maximum torque @ 1400 rpm, N.m	2779
Number of cylinders	6
Cylinders displacement, l	14,9
Cylinder diameter, mm	137
Piston stroke, mm	169
Specific fuel consumption at rated power, g/kW hr	209
Air cleaning is performed by three-stage filter with dry-type elements. Engine exhaust expulsion is performed through dump truck body. Mixed-type lubrication system is designed with "wet" crankcase. Fluid cooling system with forced circulation is integrated with cooling system of hydromechanical transmission and multiple-disk oil-cooled brakes. Oil cooling is performed by oil-to-water heat exchangers. Starting system is actuated by electric starter.	
Electric equipment system voltage, V	24

<b>Transmission</b>		
Hydromechanical transmission is equipped with complex one-stage four-wheeled torque converter with automatic locking, four-shaft gearbox with multiplate friction clutches and electrohydraulic actuator of gear change control, manual gear change control.		
Maximum dump truck travel speed, km/h		55
Hydromechanical transmission 5+2 gearbox ratios:		
gears	forward	reverse
1	3,84	6,07
2	2,27	1,67
3	1,50	
4	1,055	
5	0,625	

<b>Suspension</b>	
Suspension is conventional for front axle and driving axle and equipped with trailing arms, central joints and transversal rods. Cylinders are pneumohydraulic (nitrogen and oil) and equipped with inbuilt hydraulic shock absorber. Two cylinders are on the front axle and two cylinders are on the rear axle.	
Cylinder piston stroke, mm	
- front	300
- rear	270

<b>Steering</b>	
Hydrostatic steering with steerable front wheels.	
Steering angle, degree	41
Turning radius, m	9,0
Overall turning diameter, m	20
The steering meets ISO 5010 requirements.	

<b>Brakes</b>	
Dump truck brake system meets ISO 3450 international safety regulations and requirements. The system is equipped with service, parking, auxiliary and emergency brake systems.	
<b>Service brake system</b> is dry-type single-disk brakes for front wheels and multiple-disk oil-cooled brakes for rear wheels. Actuator is hydraulic and separate for front and rear wheels.	
<b>Parking brake system</b> is disk brake on final drive driving shaft with spring actuator and hydraulic control.	
<b>Auxiliary brake system</b> uses rear wheels multiple-disk oil-cooled brakes with hydraulic actuator. Braking by service brakes with the view of deceleration is effected by separate foot pedal.	
<b>Emergency brake system</b> uses operable circuit of service brakes.	

<b>Hydraulic system</b>	
Hydraulic system is combined for body dumping gear, steering and brakes actuator. The system is equipped with gear-type oil pumps, two-stage telescopic body lifting cylinders with one stage of double action.	
Body lifting time, s	15
Body lowering time, s	14
Maximum pressure in hydraulic system, MPa	17
Maximum pump delivery @ 2100 rpm, dm <sup>3</sup> /min	342
Filtration degree, mcm	10

## Body

Welded bucket-type body with FOPS safety system, protective canopy, engine exhaust heating, device for mechanical fixing in raised position and rock-ejectors.

Body capacity, m<sup>3</sup>:

struck                      heaped 2:1  
21,5                         27,7



## Frame

Frame is welded of high-strength low-alloy steel with application of cast elements at the maximum loading points and equipped with box-section variable-height side-members interconnected by cross-members.

## Driving axle

Mechanical driving axle is equipped with single-stage bevel final drive, bevel differential and planetary hub drives with spur pinions.

Ratios:

final drive	3,417
hub drive	6,0
driving axle total	20,50

## Driveline

Driveline consists of two open-type cardan shafts with joints on needle bearings that join hydromechanical transmission to engine and driving axle. Flexible coupling is mounted between front cardan shaft and engine.

## Cab

Two-man two-door cab is equipped with air-sprung adjustable driver seat, additional trainee seat and adjustable steering column. The cab meets EN 474-1 and EN 474-6 requirements that specify permissible levels of in-cab noise, vibration, content of hazardous substances and dust.

Driver's workplace meets ROPS safety requirements.

In-cab noise level is not more than 80 dB(A).

Local vibration level is not more than 126 dB(A).

Overall vibration level is not more than 115 dB(A).

## Tires

Tubeless air tires with quarry tread pattern.

Tire designation	21.00-35/21.00R35
Inflation pressure, MPa	0,575/0,7
Rim designation	15.00-35/3.0

## Overall dimensions, mm\*

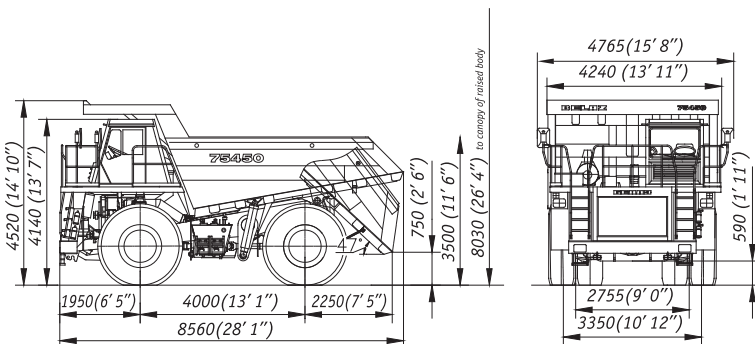

\*Overall dimensions are specified for basic kitting-up of the dump truck

## Weight

Maximum payload capacity, kg	45000
Unladen weight, kg	35000
Gross weight, kg	80000
Dump truck weight distribution on axles, %:	
front	unladen 54,0      laden 34,0
rear	46,0                66,0

## Refill capacities, l

Fuel tank	740
Engine cooling system	148
Engine lubrication system	53
Hydromechanical transmission	105
Hydraulic system	300
Final drive	32
Hub drives	32 (16x2)
Suspension cylinders:	
front	30(15x2)
rear	31,7 (15,86x2)

## Special equipment

- Fire-fighting system (standard)
- Heating and conditioning unit (standard)
- Preheating system (optional)
- Centralized lubrication system (optional)
- Telemetering tire-pressure monitoring system (optional)
- Dry disk brakes (optional)

## Towing and braking performance

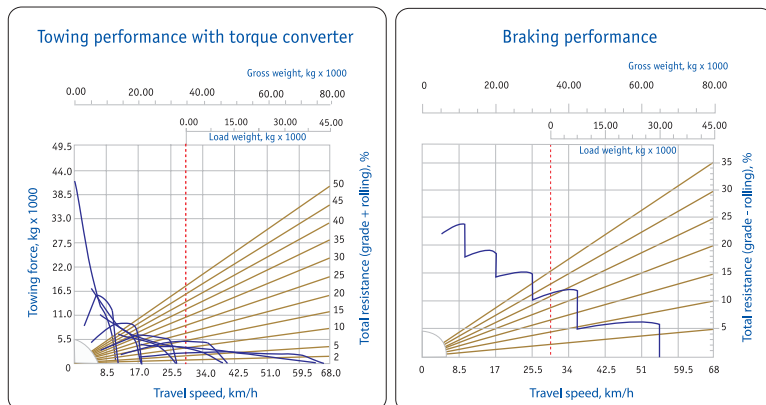

OJSC "Belarusian Autoworks" (BELAZ)  
40 let Oktyabrya str. 4, 222160, Zhodino, Republic of Belarus  
phone: +375 1775 3-60-67, 3-37-37, 3-27-82  
fax: +375 1775 7-01-37  
e-mail: office@belaz.minsk.by  
www.belaz.by