

BH 40

REAR DUMP TRUCK



Salient Features

- **The Robust Truck.....**
- **Performance :** High power BEML BSA6D 140-1 engine, rugged transmission with automatic lock-up clutch and heavy-duty planetary axle provide optimum combination of speed and tractive effort.
- **Productivity :** High power to weight ratio gives ample reserve power for faster cycle time.
- **Reliability :** Adjustment free wet multiple disc brakes for rear axle and dry caliper disc brakes for front axle offer high availability
- **Serviceability :** Low maintainability and reparability index, evaluated through SAEJ817A, compared to any other dumper in its class.
- **Manoeuvrability :** Orbitrol power steering with a good combination of steering angle, shorter turning circle dia, wheel tread and wheel base.
- **Comfort :** Ideally located spacious cabin with ergonomically designed operator control offer maximum comfort and operational ease.
- **Safety :** Features include Rops cabin, emergency steering, dual brake system to meet relevant safety standards.



Max. Plaload : 36,500 kg (40 ton)
Capacity (heaped) : 24 m³
SAE /ISO 2:1
Flywheel power (net) : 339 kW (455 hp) @ 2100 rpm

BH40



BH40 REAR DUMP TRUCK SPECIFICATIONS

Technical Specifications



Engine

Make	BEML
Model	BSA6D140-1
Type	Diesel, 4 stroke, turbo charged, after cooled, direct injection, water cooled.
No. of cylinders	6, inline
Bore & Stroke	∅ 140 x 165 mm
Displacement	15.24 ℓ
Flywheel power (net)	339 kW (455 hp) @ 2100 rpm
Maximum net torque	1893 Nm (193 kgm) @ 1400 rpm
Electricals	
Alternator	24 V, 45 A
Starting motor	24 V, 7.5 kW
Battery	2 x12 V, 200 Ah



Power Train

Transmission						
Model	AVTEC CLBT 5961					
Type	Powershift with lockup clutch					
Torque Converter						
Model	TC 690					
Type	3 element, single stage					
Stall ration	2.17 : 1					
Drive axle	Full floating					
Differential						
Type	Traction sensing, automatic					
Ratio	2.92 : 1					
Final drive						
Type	Planetary					
Ratio	5.53 : 1					
Total reduction	16.15 : 1					
Travel speeds (km/h)						
Range	1st	2nd	3rd	4th	5th	6th
Forward	11.0	16.4	22.0	32.6	44.0	66.0
Reverse			8.6			



Steering system

Type	Orbitrol, full time power steering
Cylinder	
Type	Double acting piston type
Quantity	Two
Bore x Stroke	∅ 110 x 435 mm
Relief pressure	12.3 MPa (125 kg/cm ²)
Emergency steering	Electrical supplemental steering is standard
Turning angle	42°
Vehicle clearance diameter	17.08 m



Frame

Type	Box section construction made of high tensile strength steel
-------------	--

Performance

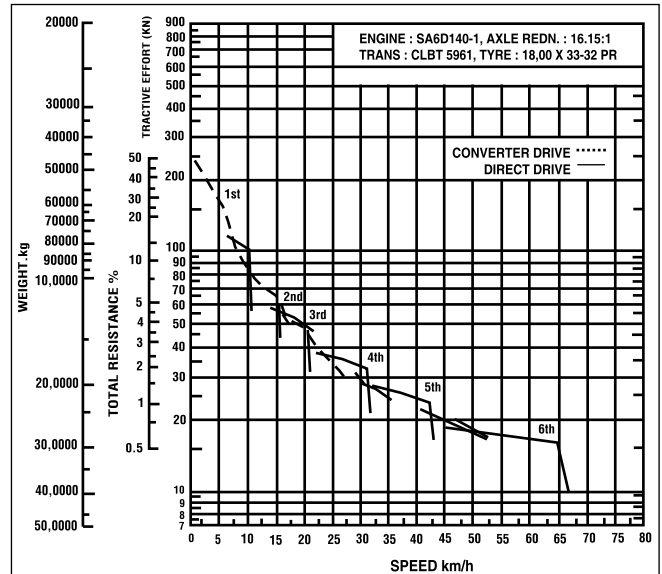

How to use this chart :

1. Enter chart at weight (gross vehicle weight)
2. Determine total resistance(grade plus rolling resistance)
3. Connect point on weight scale with point on total resistance scale and project it to tractive effort scale. Read required tractive effort.
4. Read horizontally from required tractive effort to intersect to appropriate curve. Project down to speed scale
5. Read vehicle speed for given weight and total resistance.



Brakes

Service Brakes	
Front	Air-over-hydraulic, dry caliper disc
Rear	Air-over-hydraulic, oil cooled multiple disc
Emergency brakes	Air-over-hydraulic, automatic application on both rear and front through relay emergency valves.
Parking brake	Disc type parking brake
Retarder brakes	Rear brake serves as retarder brake (Meets the SAEJ 1473 Oct 90, ISO 3450-1985 standards)



Hydraulic system

Hydraulic pump	Hoist & Steering	Brake oil Cooler
Type	Gear pump	Gear pump
Capacity	218 ℓ/min @ 2100 rpm	218 ℓ/min @ 2100 rpm
Rotation	Counter clockwise	Clockwise
Relief pressure	17.2 MPa (175 kg/cm ²)	0.54 MPa (5.5 kg/cm ²)
Hoist cylinders	Two, 3-stage, double acting, telescopic type	
Body hoist time	17 seconds	



Suspension

Type		
Front	Wheel mounted, hydro-pneumatic, integral rebound control	
Rear	Axle mounted, inverted hydropneumatic, integral rebound control	
Cylinder	Front	Rear
Quantity	2	2
Bore x stroke	Ø 216 x 365 mm	Ø 216 x 170 mm
Charging pressure	2.8 MPa (28.12 kg/cm ²)	1.9 MPa (19.5 kg/cm ²)
Load/ Deflection rate		
Empty	549 kg/cm ²	651 kg/cm ²
Loaded	1181 kg/cm ²	10220 kg/cm ²



System Refill Capacities

Systems	Capacity (Litres)
Cooling systems	120.0
Fuel tank	540.0
Engine lube oil	38.0
Transmission & torque converter	70.0
Final drive	40.0
Hydraulic tank	225.0
Air tanks	150.0
Suspensions - Front	17.0
- Rear	8.8

Body (Exhaust Heated)

Plate thickness	
Bottom Plate	20 mm
Side plate	10 mm
Front plate	12 mm
Target area (length x width)	5285 x 3475 mm
Depth	1475 mm
Volumetric capacity	
Struck	18 m ³
Heaped - SAE/ISO (1:1)	29 m ³
- SAE/ISO (2:1)	24 m ³
- SAE/ISO (3:1)	22 m ³



Tyres

Size (Front & Rear)	18.00 x 33, 36 PR(E-4) tubeless Standard
	18.00 x 33, 32 PR(E-3) - Optional
	18.00 x R33 Radial- Optional
Rim size	13.00 x 33
BEML recommends the user to evaluate all job conditions and consult the tyre manufacture to make proper tyre selection.	



Cabin

Type	Integral ROPS cabin provided with tinted safety glass and electronic display dashboard (Meets ROPS performance criteria as per ISO 3471)
------	---



Masses

Net vehicle mass	32,090 kg	
Rated payload	36,500 kg	
Gross vehicle mass	68,590 kg	
Mass distribution	Empty (kg)	Loaded (kg)
Front axle	15,082 (47%)	22,635 (33%)
Rear axle	17,008 (53%)	45,955 (67%)

Standard Accessories

GENERAL :

Integral ROPS cabin, Electronic Diagnostic system, Vandalism protection caps (radiator & Fuel tank), Head and tail lights, Horn valve, Turn signal lights, Alternator, Electric starter, Key-switch, Wiper motor, Emergency steering motor, Windshield washer, Dump brake, Right & left hand mirror, Portable fire extinguisher, Tool kit, Parking brake valve, Tilttable steering wheel and column, Exhaust heated body, Central warning lamp & buzzer, Battery Relay, Backup alarm with Flasher, Catwalk, Mudflaps, Body lock pins, Rock ejectors, Cabin floor mat, Safety seat belt, Co-operate seat, Air dryer.

GAUGES

Ammeter, Voltmeter, Air pressure, Engine oil pressure, Water temperature, Transmission oil temperature & pressure, Brake oil temperature, Air cleaner restriction, Speedo meter, Tacho-meter, Electrical hour meter, Fuel level and Gear shift indicator.

GUARDS

Engine belly guard, Cab spill guard, Drive line protector, Rock guard and hand rial.

INDICATORS

Hi-beam, Reverse, Turn signal, Body-up, Lube oil pressure, Water temperature, Parking brake and emergency steering "ON", Alternator warning, Air pressure, Hydraulic oil temperature, Transmission oil temperature and pressure, Fuel level & transmission filter clogging.

ALARMS

Air pressure, Water temperature, Transmission oil temperature & pressure, Lube oil pressure, Hydraulic oil temperature, Transmission filter clogging, Body-up and parking brake "ON".

OPTIONAL ACCESSORIES

M6610A Transmission with CEC2 controls. Tyre inflation kit, Suspension charging kit, Auto emergency steering, Air conditioner and heater unit, Radial tyres, Exhaust muffler (for non heated body), Wiper & washer for cab rear glass, Automatic centralised lubrication system. Automatic fire suppression system.

Dimensions

in mm

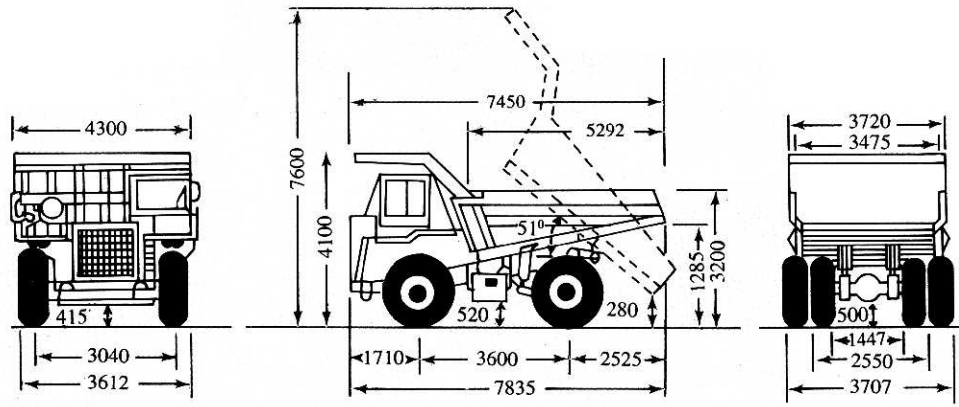

1. Illustrations may include optional equipment © accessories and may not include all standard accessories.
2. Materials and specifications are subject to change without notice.
3. All the specifications meet relevant ISO standards.

www.bemlindia.com



Form No. : BH40/03/09/2009