



CAPACITY
REVGROUP

Capacity Stock Truck Specs: Sabre 4x2 / Off-Highway



Six ways Capacity gives you a distinct edge in your operation.

1. DURABILITY

Through exhaustive validation and testing to create *SabreFrame* and backing it with the industry-leading *SabreShield* structural warranty

2. RELIABILITY

Engineered into every aspect of Sabre's operation, from the automotive bundling and routing with an exclusive, sealed multiplex Body Control Module to our cab door with 96,000 cycles of testing

3. SERVICEABILITY

Access360 Serviceability with numerous engineered accommodations to ease service and maintenance, including numerous service checks that can be accessed from ground level

4. CUSTOMIZATION

The industry leader in choices and configurations

5. COMFORT AND SAFETY

Driver-optimized features such as *SabreTuned* Seat and Cab Suspension System that promote safe and productive operation

6. CUSTOMER CARE

Thorough and responsive attention to your needs through our exclusive customer promise: C3—the Capacity Customer Commitment

Capacity Stock Truck Specs: Sabre 4x2 / Off-Highway

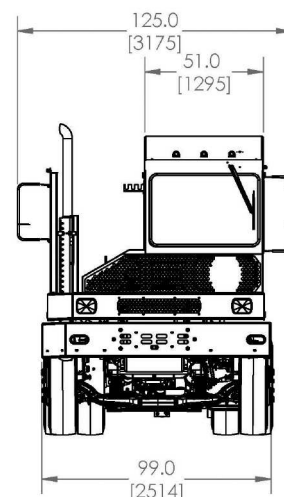
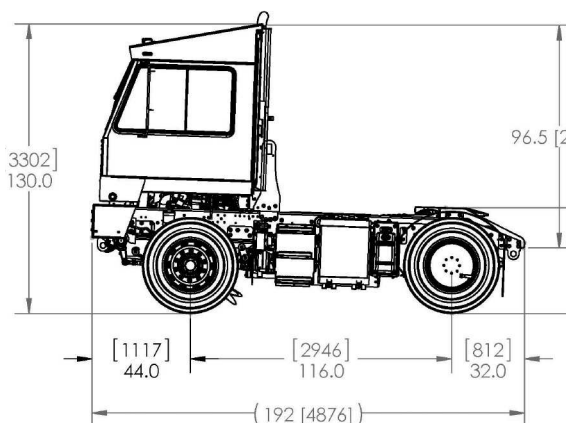
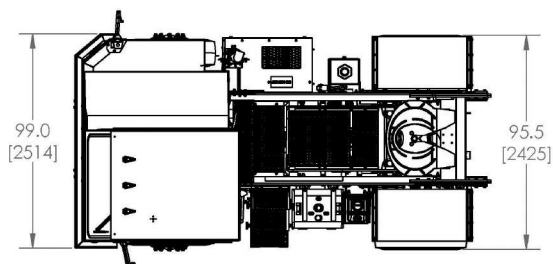

SABRE 4X2 / OFF-HIGHWAY

GCWR: 81,000 Wheelbase: 116"
Axle: 4x2 Cab: 66"

POWERTRAIN

Cummins QSBT4-Final 6.7L 164 Horsepower,
2300 RPM Turbocharged and
Charge Air Cooled

3-Way Shutdown Low Oil PSI,
High Coolant Temp, Low Coolant Level

Air Cleaner Filter

Air Intake Restriction Gauge -
Engine Mounted

Vertical Exhaust System

Exhaust Heat Shield

130 Amp Alternator

Denso Starter

Silicone Coolant Hoses

Allison RDS-3000

Meritor FF-961 12,000 lb. Capacity

Meritor RS24-160 7:17:1 Ratio
30,000 lb. Terminal Rating

Dunlop SP160 11K22.5 Rib Tires

Standard Valve Stems, TR-572 (0°)

CHASSIS

Group 31, 750 CCA Maintenance-Free
Batteries (2)

Hydraguide Steering

Front Tire Flaps

Standard Capacity Bumper

50-Degree Taper Curbside Deck and Bumper

Frame Structure 116" 82" Between Cab &
Center 5th Wheel (In Up Position) and Cab

Front Tow Eye

Rear Tow Eye

Three Drain Pull Cords

50-Gallon Fuel Tank

Front Leaf Suspension 10L-9R

Rear Rigid Suspension

SAF Holland FW35 - 70,000 lb. Lift Capacity

5th Wheel Lift Height 16"

Backup Alarm

Recessed Rear/Stop Lights &
Back-Up Lights - LED

CAB

Five Top-of-Cab Clearance Lights - LED

Standard Mirrors

National 2000 Series Vinyl Mid-Back Driver's Seat
Seat Belt - Black Lap

Standard Steering Column

66" Cab

Keyed Ignition

Electric Intermittent Windshield Wipers

Volt Meter, Oil Pressure, Water Temperature,
Fuel Level, Air Pressure, Hour Meter,
Speedometer, Odometer

High Beam Headlight Indicator, Turn Signal-Hazard
Flasher Indicator, Low Fuel, Low Air
& Low Engine Oil Pressure Light & Buzzer

12' Coiled Trailer Air Hoses

Standard Red & Blue Glad Hand

45,000 BTU Heater/Defroster

Dome Light

Head Lights

OTHER STANDARD FEATURES

Standard Bumper Paint Black

Standard Cab Paint White

Standard Wheels Painted White

Standard Steps, Grates & Handrails
Paint "Safety Yellow"

Standard Platform Paint White

Standard Frame Paint Black

CAPACITY STOCK STANDARD OPTIONS

4-point Air Ride Cab

AD-IP Air Dryer

Cab Guards

Coolant Recovery Bottle

Flexible Rear Fenders

Tire Flaps Behind Drive Axle, w/ Capacity Logo

12V Auxiliary Power Socket

Power Terminal Overhead

Air Conditioning

Amber Strobe Light

Windshield Washer

Worklight, One Rear-facing Curb Side
Platform-mounted - LED

Worklight, One Rear-facing Driver Side
Roof-mounted - LED

8" Convex Mirrors

Translucent Sun Visor