

561 M

Pipelayer



Cat® 3116 Diesel Engine

Power shift

Gross horsepower	90 kW	121 hp
Flywheel horsepower	82 kW	110 hp
Operating weight	16 240 kg	35,804 lb
Lift capacity	18 145 kg	40,000 lb

561M Pipelayer

An outstanding choice for productivity and versatility.

Power Train

✓ Perfectly matched power train. From the powerful and fuel efficient 3116 DIT engine to the durable power shift transmission, all Caterpillar® components work together to deliver responsive power when you need it. **pg. 4-5**

Structure

Mainframe is designed and built for durability using the latest technology in engineering and manufacturing. It provides solid support and perfect alignment for major components. **pg. 6**

Undercarriage

The elevated sprocket moves the final drives above the work area, isolating them from ground impact for long power train component life. **pg. 7**

Engineered to exceed the most demanding goals.

The 561M's increased power and versatility, combined with rugged components, are designed for tough and varied working conditions. This machine offers you the reliability and durability you expect from Cat Pipelayers.





Operator's Station

Ergonomically designed for maximum productivity and comfort. Controls are intuitive, low-effort and easy to reach, viewing area is excellent, instrument panel is easy to read and informative, and storage space has been increased. **pg. 8**

Pipelayer

Fully hydraulic load line and boom winches provide excellent speed capability. Counterweight and frame design provides excellent stability while **✓ offering increased viewing area. pg. 9**

Operator's Station Access

✓ Simplified entry by *adding a ladder on the right rear side* of the machine. **pg. 8**

Serviceability

Major modular components are designed for excellent serviceability and allow fast in-field component exchange. **pg. 10**

Customer Support

Excellent parts availability and the best service capability help increase productivity. **pg. 10**

✓ *New feature*

Power Train

The Caterpillar 3116 engine, optimally matched with torque converter and power shift transmission, provides an excellent balance between efficiency and power.



Cat 3116 engine. Caterpillar 3116 engine performs at full-rated net power of 82 kW (110 hp) at 2100 rpm with high torque rise of 36%. High horsepower, combined with high torque rise, give the 561M the durability needed on the challenging jobs. Plus, this engine meets all the latest emission regulations around the world.

Turbocharging improves response and performance at low to medium engine speeds.

Direct unit injection fuel system eliminates external high pressure fuel lines and provides excellent control of injection timing with individually metered, high-pressure, direct-injection of fuel. Result is improved engine response and reliability plus low fuel consumption and emissions.

Resilient engine mounting for quieter operation and less vibration.

Long-life design

- One-piece, stress relieved, cast iron cylinder block for increased rigidity.
- High-strength, one-piece cylinder head with replaceable stainless steel intake valve seat and nickel alloy exhaust valve seat.
- Optimized camshaft location, short pushrods and roller followers to reduce flexing.
- Full-length, water-cooled cylinders for maximum heat transfer.
- Large engine oil cooler to maintain optimum engine oil temperature.
- Main and rod bearing surfaces increased for better wear life.
- Two piece articulated piston with forged steel crown for added durability.
- Low-mounted oil pump for quick start-up lubrication.

Easy maintenance. The engine can be rebuilt for a second life. Caterpillar remanufactured parts are available to economically replace many components. Some innovative maintenance features of the 3116 engine:

- Parent-metal cylinder block can be rebored twice and dry-sleeved.
- Connecting rods can be removed through the tops of the cylinders.
- Camshaft followers and pushrods can be easily replaced without removing the camshaft.
- Water pump can be serviced as a unit or rebuilt.

Improved multiple row modular radiator efficiently cools the engine for optimum engine performance in tough environments and applications.

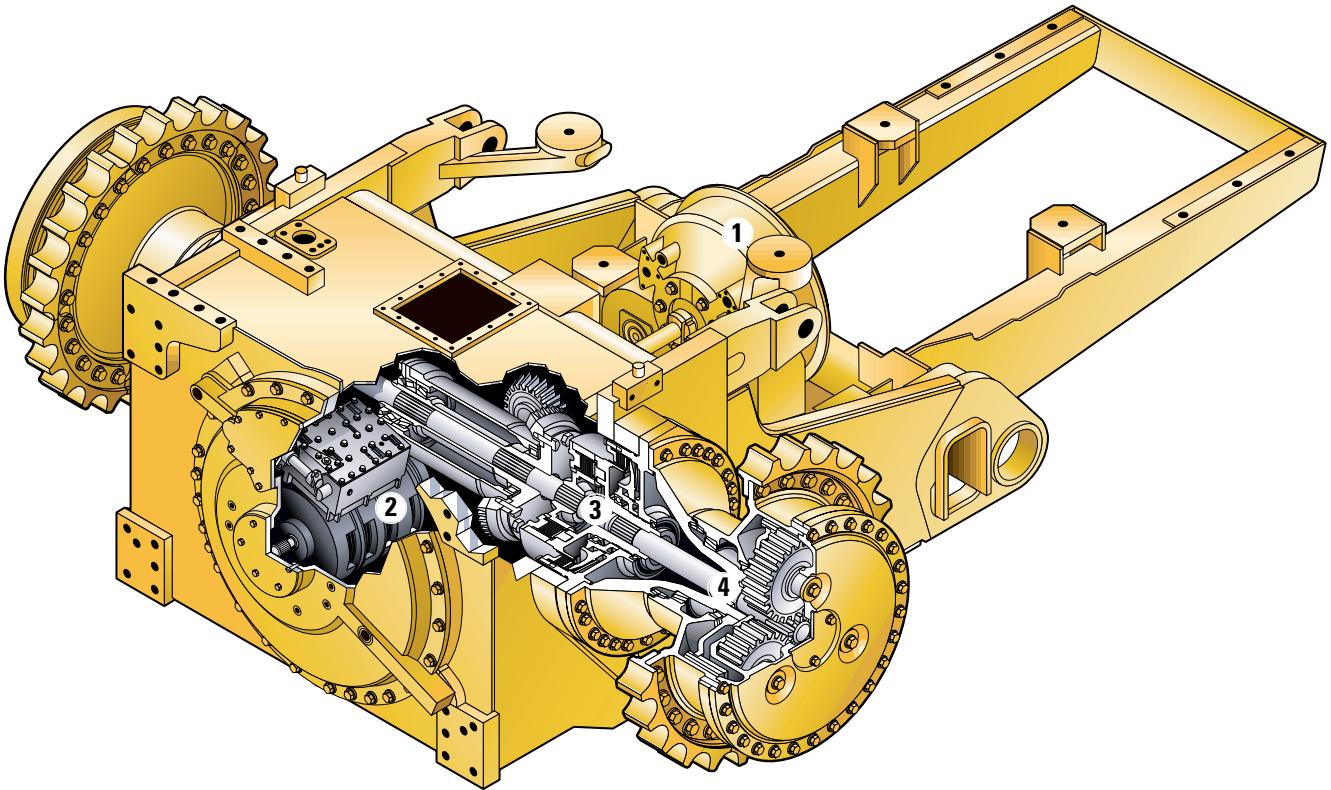

Drivetrain components are matched and balanced to deliver exceptional performance and durability.

1 Torque converter responds to changing load conditions by providing torque multiplication for increased drawbar pull while protecting the drive train from shock loads.

2 Power shift transmission. Proven planetary design delivers fast, smooth speed changes while distributing loads over multiple gears for long life. Perimeter-mounted clutches provide superior heat dissipation and a large contact area for long service life.

3 Separated clutches and brakes. Oil-cooled, hydraulically actuated multiple-disc clutches and brakes for smooth, precise turns.

4 Final drives. Precision, high load capacity gears and bearings give long-lasting performance and durability.

Structures

Engineered and manufactured to provide durability in the most demanding work.

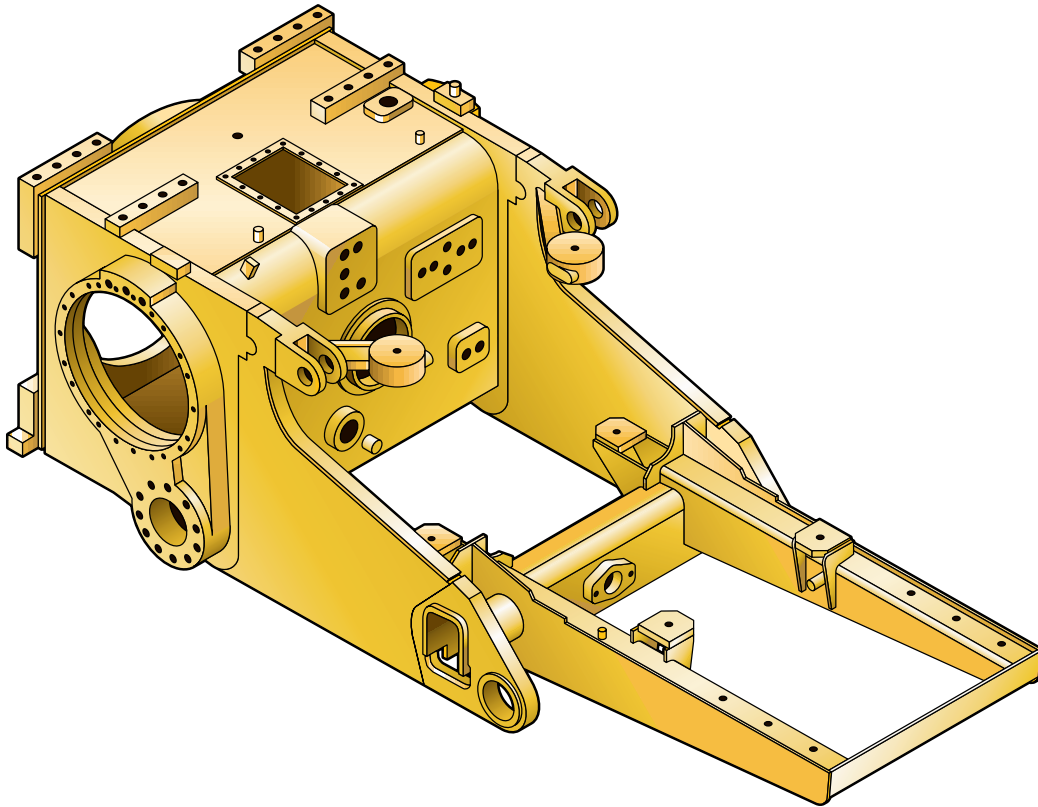

High strength steel mainframe. The 561M mainframe absorbs high impact shock loads and twisting forces.

Structural testing analysis is used to verify and ensure integrity of the mainframe.

Robotic welding provides deep penetration and consistency for long life.

Precision top level machining for perfect alignment of bores and surfaces.

Roller frames are tubular, to resist bending and twisting, with reinforcement where operating stresses are the highest.

- Non-oscillating roller frames for greater stability in pipelaying applications.
- The recoil system is sealed and lubricated.
- Improved pipelayer structure mounting.



Undercarriage

The Caterpillar elevated sprocket undercarriage arrangement is designed for better balance, performance and component life.



Final drives and associated power train components are raised above the work area, isolating them from ground-induced impact loads, as well as pipelayer loads, extending power train component life.

Sprocket position keeps sprocket teeth, bushings and final drives away from the abrasive materials and moisture, resulting in longer final drive gear and seal life.

High flange improved track rollers (optional) combined with center or full length roller guard attachments greatly improve track guiding for demanding side slope conditions.

Track shoes are 510 mm (20") single grouser shoes made from heat-treated, rolled steel for added strength. Long track frame and wide gauge enhance track contact area, providing a very stable working base.

1 Heavy Duty Sealed and Lubricated Track

Permanently coats the track pin with a sealed-in lubricant, minimizing metal-to-metal contact.

- Virtually eliminates internal pin and bushing wear.
- Lubricant is held in a reservoir in the track pin.

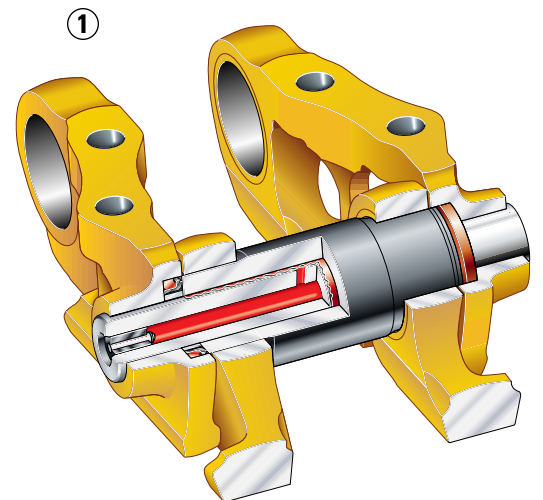

Operator's Station

Ergonomically designed for operator's maximum comfort and productivity.



1 Operator's station provides excellent comfort and convenience. The new counterweight design provides improved viewing area from the machine.

2 Pipelayer steering clutch levers are easy-to-reach, low-effort controls. They are independently actuated for sure, precise steering.

3 The seat is ergonomically designed and fully adjustable for maximum comfort. The seat cushion reduces the pressure on the lower back and thighs while allowing unrestricted arm and leg movement.

4 Instrument panel is the Electronic Monitoring System (EMS) for monitoring critical machine functions. There is also a gauge group displaying fuel level, coolant, and power train oil temperatures.

5 Separated brakes are independent of the steering clutch function to give the machine precise steering control.

6 Pipelayer controls are low effort and allow simultaneous, precise positioning of the load line and boom.

7 Load line speed range is controlled by a push-pull knob that allows the operator to select high or low.

8 Counterweight control adjusts the position of the counterweight for added machine stability.

9 Access to the operator's station is enhanced by the addition of a ladder.



Pipelayer

Caterpillar pipelayer system includes winch and boom, counterweight and frame.



Winch and Boom

- Boom and hook drawworks are driven by independent hydraulic winches.
- Oil-disc brakes provide smooth operation, positive retention of boom and hook positions.
- Modular design allows fast replacement, easy field service and testing.
- Infinitely variable speed controls for both boom and hook allow precise control.
- Tubular, cast-steel boom is rugged, delivers better fatigue life.
- Replaceable boom-mount bearings.
- Symmetrical boom simplifies installation.
- Emergency free-fall function on load line control allows the operator to drop the load quickly.



Counterweight and Frame

- New counterweight design offers improved viewing area while traveling or working.
- Main frame consists of box-section frame welded to cast bevel gear case.
- Counterweight is extended hydraulically for improved load balance, visibility and clearance.
- Service latch mechanically locks counterweight in extended position.

Drawbar

- Upsized.
- Larger jaw opening and pin diameter.
- Able to tow wider range of attachments.



Service

Modular design concept moves Cat elevated sprocket pipelayers a generation ahead in simplified service and repair.

Modular design of power train components permits fast removal and installation.

Pre-testing modular components before installation or after repair assures high quality.

Grouped service points and excellent access to service areas make routine checks fast and convenient.

Quick, easy service access and inspection of daily maintenance items.

Pressure test points for powertrain and hydraulic systems are provided.

Electrical system diagnostic connector enables fast troubleshooting of starting and charging problems.

Modular cooling system, with individual core assemblies, provides improved serviceability, reduced replacement costs and improved durability.



Caterpillar Remanufactured starters, alternators, cylinder heads, short blocks, engines, oil pumps and final drive hubs are available for fast, economical repairs.

Ecology drains provide an environmentally safer method to drain fluids. They are included on the radiator, hydraulic tank and major power train components.

Total Customer Support

Unmatched in the industry!

Your Cat dealer offers a wide range of services that can be set up under a customer support agreement when you purchase your equipment. The dealer will help you choose a plan that can cover everything from machine and attachment selection to replacement, to help you get the best return on your investment.

Selection. Make detailed comparisons of the machines you are considering before you buy. How long do components last? What is the cost of preventive maintenance? What is the true cost of lost production? Your Cat dealer can give you precise answers to these questions.

Purchase. Look past initial price. Consider the financing options available as well as day-to-day operating costs. This is also the time to look at dealer

services that can be included in the cost of the machine to yield lower equipment owning and operating costs over the long run.

Operation. Improving operating techniques can boost your profits. Your Cat dealer has training videotapes, literature and other ideas to help you increase productivity.

Machine management services — Cat dealers help manage equipment investments with:

- Custom Track Service.
- Effective preventive maintenance programs.
- Diagnostic programs like Scheduled Oil Sampling and Technical Analysis.
- Information to make the most cost-effective repair option decisions.
- Customer meetings, training for operators and mechanics.

Replacement. Repair, rebuild or replace? Your Cat dealer can help you evaluate the cost involved so you can make the right choice.

Product support. You will find nearly all parts at our dealer parts counter. Cat dealers utilize a world-wide computer network to find in-stock parts to minimize machine down time. Save money with remanufactured parts. You receive the same warranty and reliability as new products at cost savings of 40 to 70 percent.

Engine

Four-stroke cycle, six cylinder 3116 turbocharged diesel engine.

Ratings at 2100 rpm*	kW	hp
Gross power	90	121
Net power	82	110

The following ratings apply at 2100 RPM when tested under the specific standard conditions for the specified standard:

NET POWER	kW	hp	PS
Caterpillar	82	110	—
ISO 9249	82	110	—
EEC 80/1269	82	110	—
SAE J1349	82	110	—
DIN 70020	—	—	114

Dimensions

Bore	105 mm	4.13 in
Stroke	127 mm	5.0 in
Displacement	6.6 liters	403 cu in

*Power rating conditions

- based on standard air conditions of 25°C (77°F) and 99 kPA (29.32 in Hg) dry barometer
- used 35° API gravity fuel having an LHV of 42 780 kJ/kg (18,390 Btu/lb) when used at 30°C (86°F) [ref. a fuel density of 838.9 g/L (7.001 lb/U.S. gal)]
- net power advertised is the power available at the flywheel when engine is equipped with fan, air cleaner, muffler and alternator
- no derating required up to 2300 m (7500 ft) altitude

Features

- direct injection fuel system with individual adjustment-free unit injectors
- 3-ring forged steel crown pistons with aluminum skirts
- heat resistant sil-chrome steel intake and stellite-faced exhaust valves
- forged steel connecting rods
- one-piece cylinder head designed with cast intake manifold
- cast cylinder block with oil cooler cavity cast into block
- induction-hardened, forged crankshaft that is dynamically balanced
- direct electric 24-volt starting and charging system
- two 12-volt, 100 amp-hour, 750 CCA, maintenance-free batteries
- 70-amp alternator
- plate-type, water-cooled oil cooler
- vertical-flow, steel-fin, tube-type radiator
- dry-type, radial-seal air cleaner with primary and secondary elements

Transmission

Three-speed planetary power shift, remotely mounted from engine.

Speeds with power shift transmission approximate

		km/h	mph
Forward	1	3.27	2.03
	2	5.81	3.61
	3	9.93	6.17
Reverse	1	4.01	2.49
	2	7.09	4.41
	3	12.06	7.49

Final Drives

Single reduction final drives.

Features

- isolated from ground-impact and blade-induced loads
- modular design reduces removal and installation time
- segmented sprocket simplifies replacement

Steering and Braking

Multiple disc clutches and brakes meet SAE J1026 at APR90.

Features

- hydraulically released, spring applied
- cooled by pressurized oil
- no adjustment required
- each assembly serviceable as a unit
- clutch hand controls
- two brake foot pedals
- mechanically actuated, spring applied parking brake

Heavy Duty Sealed and Lubricated Track

Heavy duty design for superior track life.

Features

- improved sealability and link rail wear life
- wider bushing strap provides improved bushing retention and resistance to bore stretching and cracking
- wider pin boss and longer pin improves pin-to-link retention
- more rail material increases link and roller system wear life
- extends undercarriage maintenance intervals
- reduces overall undercarriage operating costs

Undercarriage

Tubular design resists torsional loads.

Features

- Lifetime Lubricated rollers and idlers are directly mounted to roller frame
- Roller frames attach to tractor by pivot shaft and pinned equalizer bar
- large pivot bushings operate in an oil reservoir
- Optional high flange track guiding rollers
- recoil system fully sealed and lubricated

Track gauge	2000 mm	79"
Width of standard shoes	510 mm	20"
Length of track on ground	2619 mm	103"
Ground contact area with 510 mm (20") shoes	2.67 m ²	4120 in ²
Ground pressure 510 mm (20") shoes	59.87 kPa	8.69 psi
Number of rollers (each side)		7
Number of shoes (each side)		44

Counterweight

Provides machine stability.

Features

- fully hydraulic, single-lever control
- layout-pivot point design provides good side and ground clearance
- new design gives better visibility

Weight (approximate)

Shipping: 15 318 kg (33,770 lb)
Includes lubricants, coolant, 10% fuel, hydraulic controls and fluids, backup alarm, seat belt, 510 mm (20") single grouser shoes, drawbar, and counterweight

Operating: 16 240 kg (35,804 lb)
Includes all shipping weights plus full fuel tank, boom and pulley blocks, and operator

Hydraulic Controls

Two-section vane pump with pilot operated control valves.

Pump output at 2200 pump rpm (2100 engine rpm) and maximum pressure
211 liters/min 55.7 gpm

Relief valve setting

Counterweight 19 600 kPa 2850 psi

Hook and

boom winch 18 600 kPa 2700 psi

Service Refill Capacities

	Liters	Gallons
Fuel tank	218	57.6
Crankcase and filter	26	6.9
Transmission, bevel gear and steering clutch (includes torque converter or oil clutch)	105	27.7
Final drive (each side)	6	1.6
Boom winch	5.7	1.5
Cooling system	46	12
Implement hydraulic system (includes tank)	67	17.7
Hydraulic tank	32	8.5
Recoil spring compartments (each side)	16	4.2

Pipelaying Equipment

Hydraulic Power (55.7 GPM at 2700 PSI and 2200 RPM pump speed independent of torque converter)
(211 L/min at 18 616 kPa/186 bar)

Planetary hydraulic winches

	Hook		Boom	
	mm	in	mm	in
Drum diameter	216 mm	8.5 in	245 mm	9.63 in
Flange diameter	398 mm	15.5 in	372 mm	14.63 in
Drum length	254 mm	10 in	254 mm	10 in
Capacity (16 mm/5/8" dia)	72.85 m	239 ft	49.38 m	162 ft
Wire rope installed (16 mm/5/8" dia)	39.63 m	130 ft	25.91 m	85 ft

	Hook Speed		Boom Line Speed	
	Lo	Hi	m/min	ft/min
Line speed			46 m/min	151 ft/min
Bare drum	33 m/min	69.5 m/min		
	108 ft/min	228 ft/min		
2 part line	16.5 m/min	34.8 m/min		
	54 ft/min	114 ft/min		
3 part line	11 m/min	23.2 m/min		
	36 ft/min	76 ft/min		
Boom	5.49 m (18 ft) square section standard			
Removable counterweight	14 segments @ 177.4 kg (391 lb) each			
Total weight extendable	3270 kg (7208 lb)			

Lifting Capacity

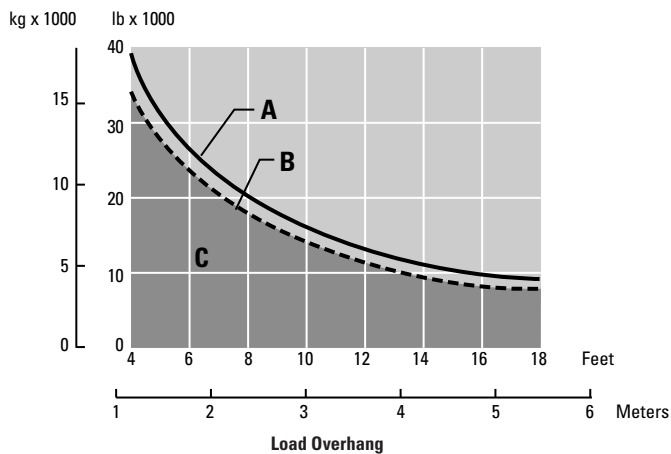

Specified Equipment

- 16 mm (5/8") diameter wire rope
- 18 688 kph (41,200 lb) minimum breaking strength
- 3 part load line
- 3 part boom line
- 3270 kg (7208 lb) counterweight extended
- boom 5.49 m (18 ft) standard
- total operating weight 16 240 kg (35,804 lb)

- A Max. lift capacity per ANSI/SAE J743 MAR92
- B Rated load capacity per ANSI/ASME B30.14
- C Working range per ANSI/ASME B30.14

Dimensions

(approximate)

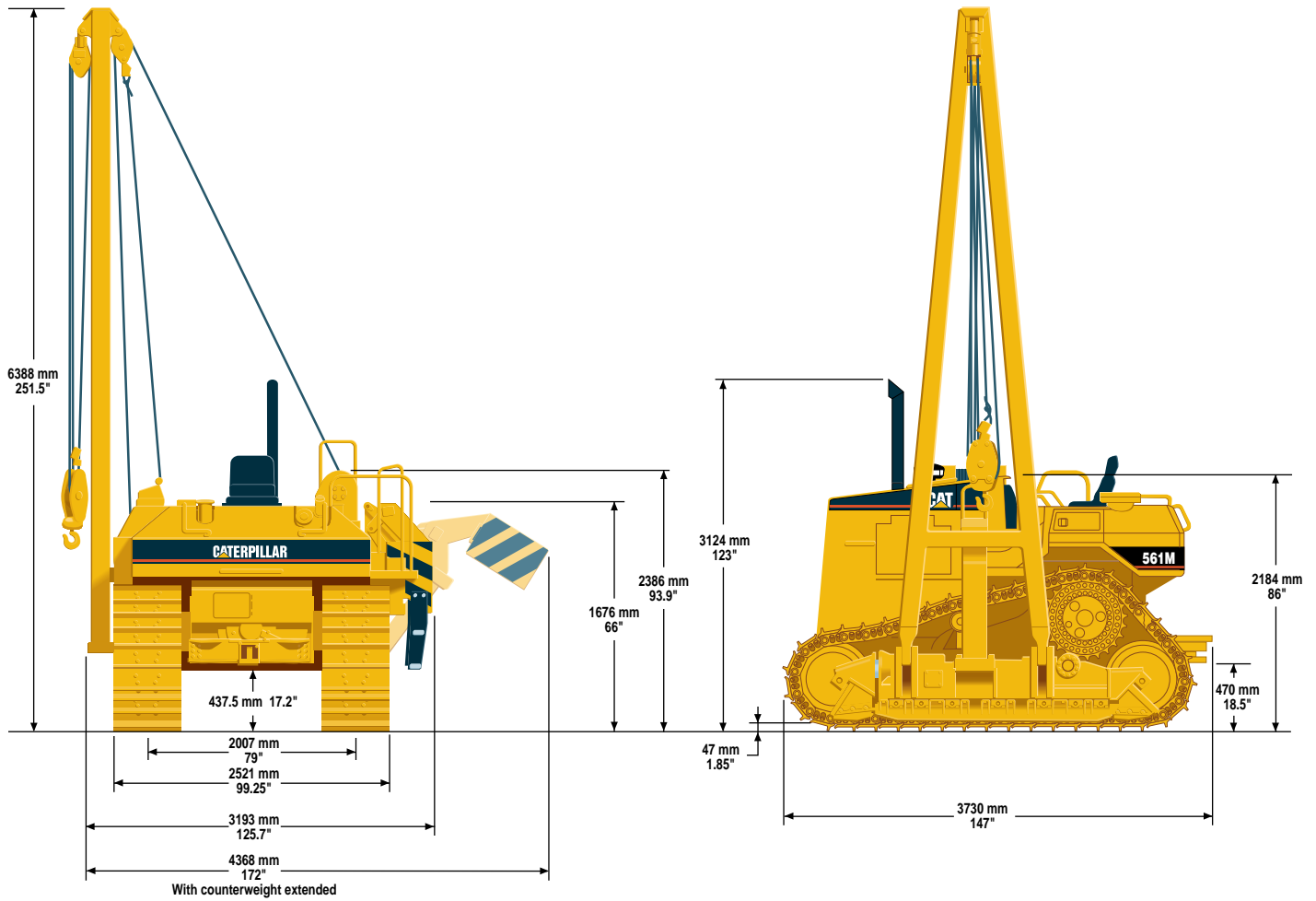

Standard Equipment

Standard and optional equipment may vary. Consult your Caterpillar dealer for specifics.

Air cleaner, dry-type, with precleaner	Engine, 3116 turbocharged diesel	Lockable storage compartment
Air cleaner service indicator	Engine enclosures, lockable	Muffler
Air intake heater	Front pull device	Precleaner
Alternator, 70-amp	Fuel gauge	Seat, vinyl suspension, with adjustable armrests
Back up alarm	Fuel priming pump	Seat belt
Blower fan	Gauge package, temperature	Segmented sprocket
Boom, 5.48 m (18 ft)	Coolant	Single key start
Brake system, service, parking and emergency	Power train oil	Steering system
Counterweight, extendible segmented 3270 kg (7208 lb)	Guards:	Lever steering
Decelerator	Center track guiding guards	Track:
Diagnostic connector (starting and charging system)	Crankcase, normal service	Adjusters, hydraulic
Diagnostic pressure taps	End guide	Carrier rollers
Drawbar, rigid	Fuel tank	Heavy Duty Sealed and Lubricated Track with single grouser track shoes 44-section, 510 mm (20")
Dual fuel filters	Instrument panel	Two-piece master link
Ecology drains	Radiator, hinged	Transmission, power shift
Electric hour meter	Rear	Vandalism protection
Electric starting, 24-volt direct	Horn	Water separator
Electronic Monitoring System	Hydraulics, pipelayer system	
	IMRM radiator	
	Lifetime Lubricated rollers and idlers	

Optional Equipment

Approximate changes in operating weights.

	kg	lb		kg	lb
Fan, reversible	11	24	Precleaner with prescreener	5	11
Guards:			Starting aids		
Crankcase extreme service	63	139	Ether starting aid		
Precleaner	7	16	Heater, engine coolant choice of 120 or 240 volt (dealer installed)	1	2
Radiator, heavy duty, hinged grill	20	44	Heavy duty batteries	42	94
Radiator core protection grid	17	38	Suspension seat, vinyl, low back	10	22
Track roller, length	146	321	Tool kit (dealer installed)	7	16
Lighting system, four lights	10	23	Track rollers, high flange	15	33

561M Pipelayer

AEHQ5238 (4-97)
(Replaces AEHQ3828-01)

© 1997 Caterpillar
Printed in U.S.A.

Materials and specifications are subject to change without notice.
Featured machines in photos may include additional equipment.
See your Caterpillar dealer for available options.

CATERPILLAR®