

740/740A

# CHAMPION<sup>®</sup> Series IV MOTOR GRADERS



MODEL	740	740A
Configuration	Rigid Frame	Articulated
Operating Weight*	38,060 lbs (17 264 kg)	38,060 lbs (17 264 kg)
Net hp/kW	210 (157)	210 (157)

\* Typically equipped; see specifications for details. Model shown may include optional equipment..



## What it takes to be a Champion

There's a fine line between a good grader and a great one. With the

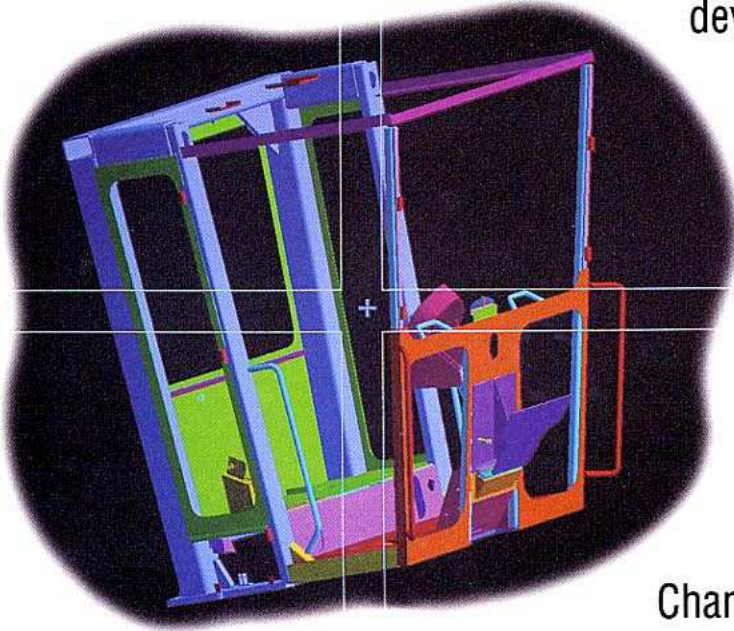

development of Series IV graders,

Champion is crossing that line to be "the best on earth" for every job your grader has to do.

*Champion's "voice of the customer" program led directly to many of the operator features introduced in Series IV.*

When it comes to cutting new roads and pushing heavy loads,

Champion has been the world's number one specialist for a long time.

Now, with Series IV, Champion moves up to first choice for fine grading, too, with a wide-ranging list of new features to enhance productivity. And Series IV also brings you a new standard in reliability engineering so, at the end of the day, you get the job done at a lower cost.

Series IV graders were designed by grader people – we put our engineers into the cab with some of the best operators in the

*Series IV is built on a solid foundation of already proven Champion features. Some of these include: the rear perimeter frame, the first user lifetime frame warranty and a hinged rear grill for easy radiator cleaning.*



business to compare ideas. We built Series IV together, with over 60 specific design recommendations.

For instance:

- a unique load-sensing hydraulic system for fine grading “featherability” and power to spare
  - a clear line-of-sight to the work zone and every area you need to see
  - a place to hang your hat
  - a 72° steering arc on the front axle for tighter turns
    - a choice of blade lift systems
    - a more comfortable place to work
    - easier access for servicing
  - a familiar “operator-friendly” cab layout



... not to mention the rock-solid construction that earned Champion graders a place on the preferred list of fleet owners around the world.

Series IV is getting the kind of support a great Champion deserves, too. Electronic parts ordering. Flexible financing options. Highly trained dealers and service staff. A warranty that says Series IV is built to live up to the name of Champion...

...the best on earth



*Champion dealers are equipped to support customers with “the best service on earth”, including next-day delivery on emergency parts ordered by 5pm local time, anywhere in the continental United States or Canada.*

# Looking out for "Number One"

That means you, because the most important part of a grader is the operator who drives it.

When you get into the cab of a Series IV grader, you'll see how every part is engineered to help the operator with the job. The roomy both-feet-on-the-floor layout, adjustable seat and pedal-controlled tilting pedestal let you fit the grader to your personal taste for a comfortable working position.

*Make yourself comfortable! Set your feet down, adjust the seat, slide and tilt the pedestal any which-way – all your controls and gauges move with you.*

The low-effort clutch and brake pedals and short-throw levers give Series IV a light touch for easy handling and fine precision. The new front window frame, blade lift mounting and front axle all align for an unobstructed line of sight to the work area. The distinctive sloped frame and ergonomic cab design combine for excellent 360° visibility close-in to the cab and wheels. All your operating gauges are up front in clear view, right on the pedestal. From your seat you can see everything you need to do the job – from the controls to the grade stakes, to both ends of the blade, straight ahead and in the curves.

This Champion is built to work as long and hard as you do. Series IV comfort features help an operator get through a full day's grading without tiring. We kept all the hydraulic hoses outside of the cab, so you don't have to worry about leaks or excess heat and noise on the inside.

*No matter what grader you have run before, you'll feel at home with the new Series IV lever arrangement and low-effort controls.*

The cab's instrumentation is arranged in a logical sequence including the 3-level M4 electronic monitoring system and the side console where your switches are arranged in proper operating order. Everything is backlit for late work.

With a busy season ahead of you, little extras can make a big difference. That's why

Champion engineers went to work on a package of thoughtful options for hard-working operators...things like a coat hook in the cab and sliding windows to catch a fresh breeze. We even created a new left-side convenience console, an exclusive Series IV option designed to help you bring some of the comforts of home to work with you.

The whole package makes Series IV a better place to work – a grader that reduces fatigue, speeds up duty cycles and does more for the money.

*Series IV options include a new left-side console with operator conveniences including a lunch box cooler, vacuum bottle, ash tray and cup-holder.*





# Series IV: 740/740A

Reliable 24V starting and electrical system with 75 amp brushless alternator.

Separate reservoirs for transmission fluid, final drive lubricant and hydraulic fluid eliminate cross-contamination between systems.

Hinged rear grill for easy radiator cleaning.

Closed center load-sensing hydraulic system for consistent response regardless of engine speed or functions engaged.

Large toolbox can also store scarifier shanks.

Differential/Final Drive produces maximum traction when locked, reduced tire wear and increased maneuverability when unlocked; cab-operated lock/unlock.

4 outboard oil disc brakes with crossover dual circuits for even braking effort and added confidence; reserve capacity provided for emergency braking.

Transmission guard enclosed at rear to prevent filling; keeps out dirt when running in reverse over windrows.

Easy access to transmission and hydraulic filters, and to routine inspection areas.

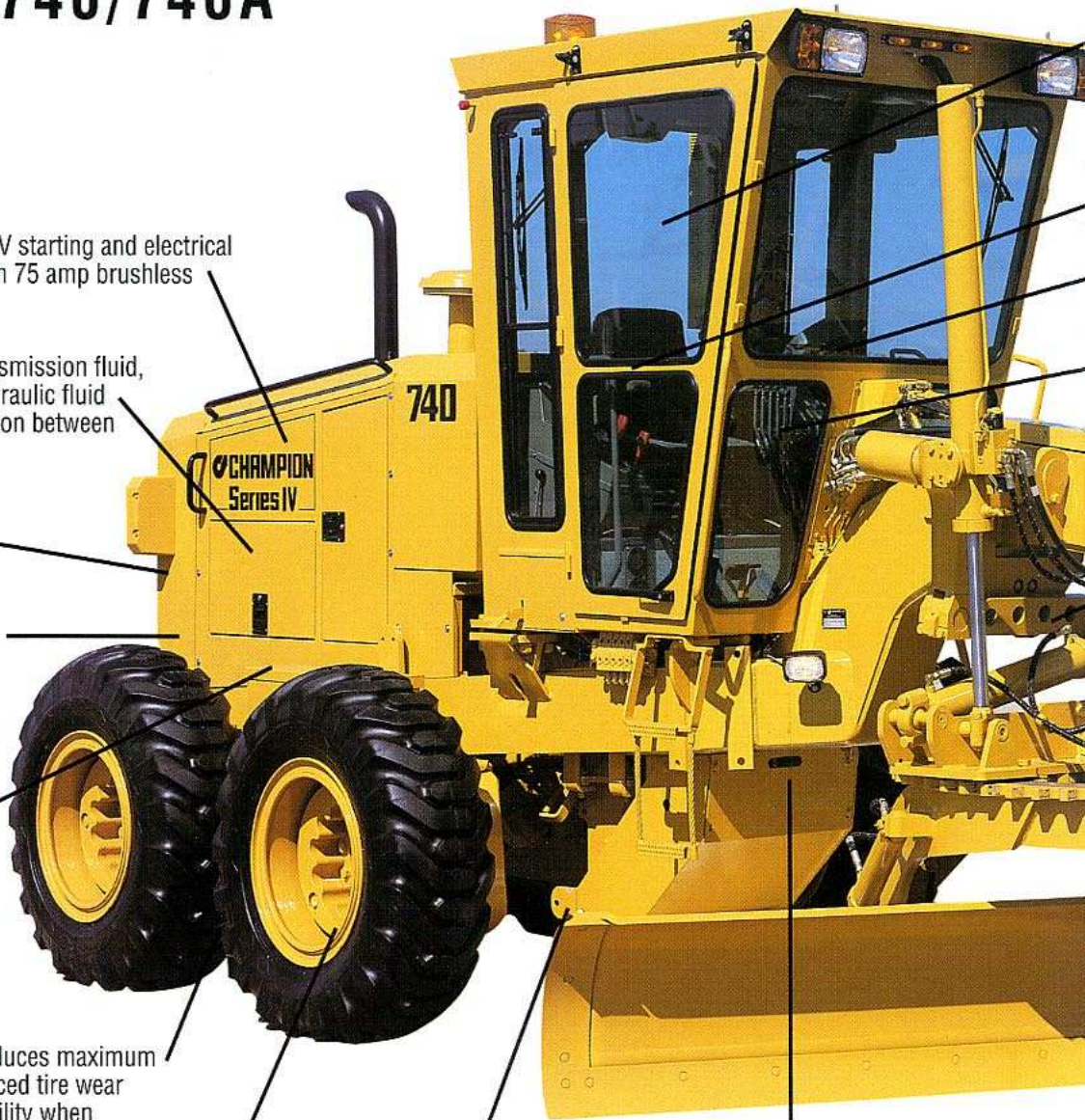

Job-matched dependable Cummins diesel power offers superior fuel efficiency as the engine's peak torque is matched to transmission shift points. Optional side panels are lockable and provide easy access for routine maintenance.



The exclusive **Champion 8400** grader transmission is now in service in more than 10,000 units. Evenly proportioned gear ratios provide precise, job-matched speeds for any grading application. A new "Smart Shift" feature lets the operator easily customize shift patterns to the job at hand.



Sloped frame for increased forward visibility. First user life time frame warranty on the front and rear frame sections.



Lift system provides widest lift cylinder stance of any grader for maximum stability and reduced end-to-end blade interaction, resulting in better fine grade control.

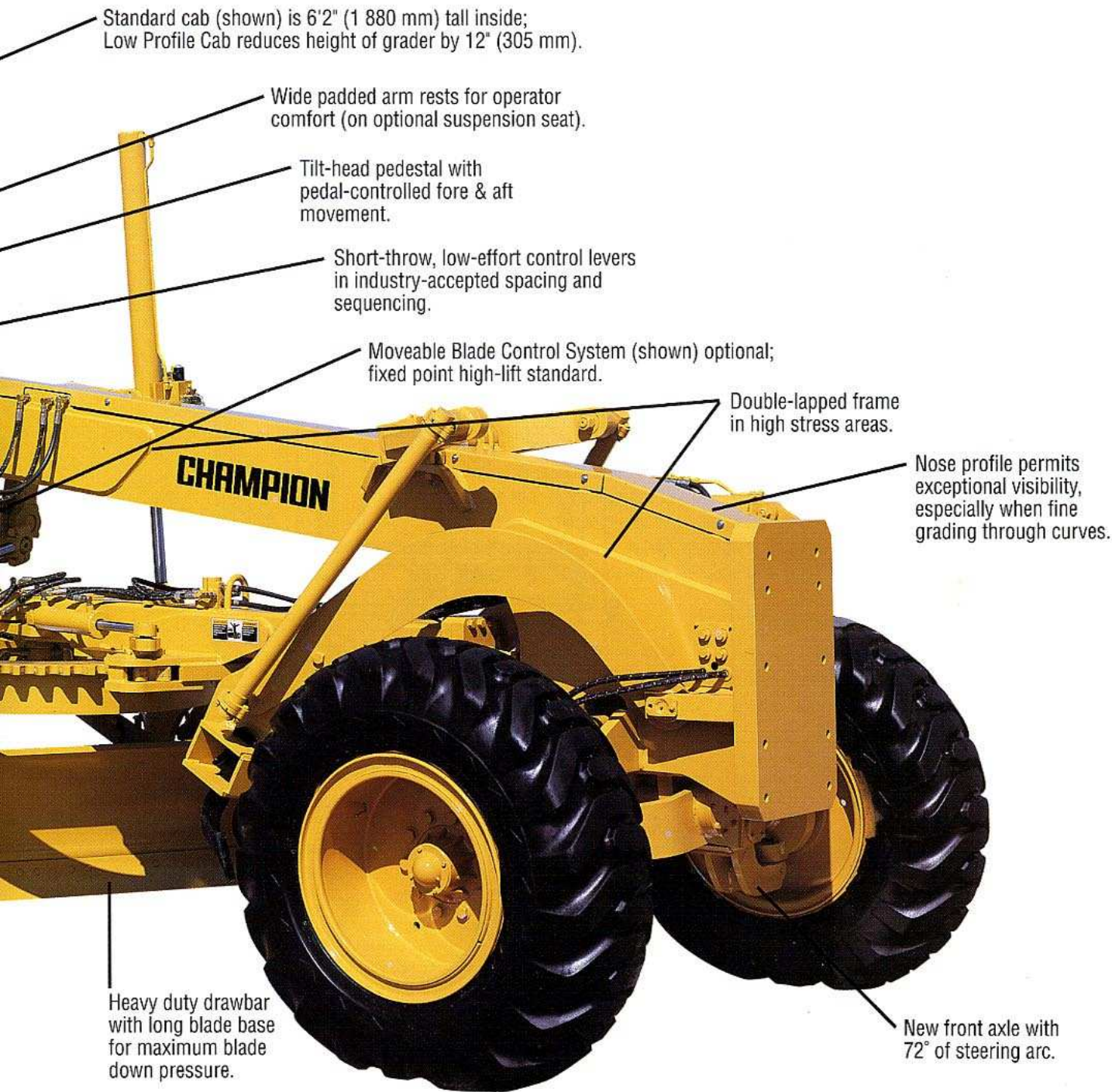

Boron steel cutting edges with 6" bolt spacing. Top and bottom slide rails are supported on DURAMIDE™ bearings, minimizing free play for fine grade control.



Pedestal includes a 3-level electronic monitor to alert operator to machine status, with backlit switches and fuel level, engine oil pressure and engine coolant temperature gauges.



Rugged design of the standard fixed-point blade lift system provides fewer moving components for low maintenance.



Patented dual-cylinder circle drive uses direct-acting hydraulics for exceptional turning and holding power under full load. DURAMIDE faced clamp plates and guide shoes prevent metal-to-metal contact; and provide longer service life and less maintenance than metallic systems.

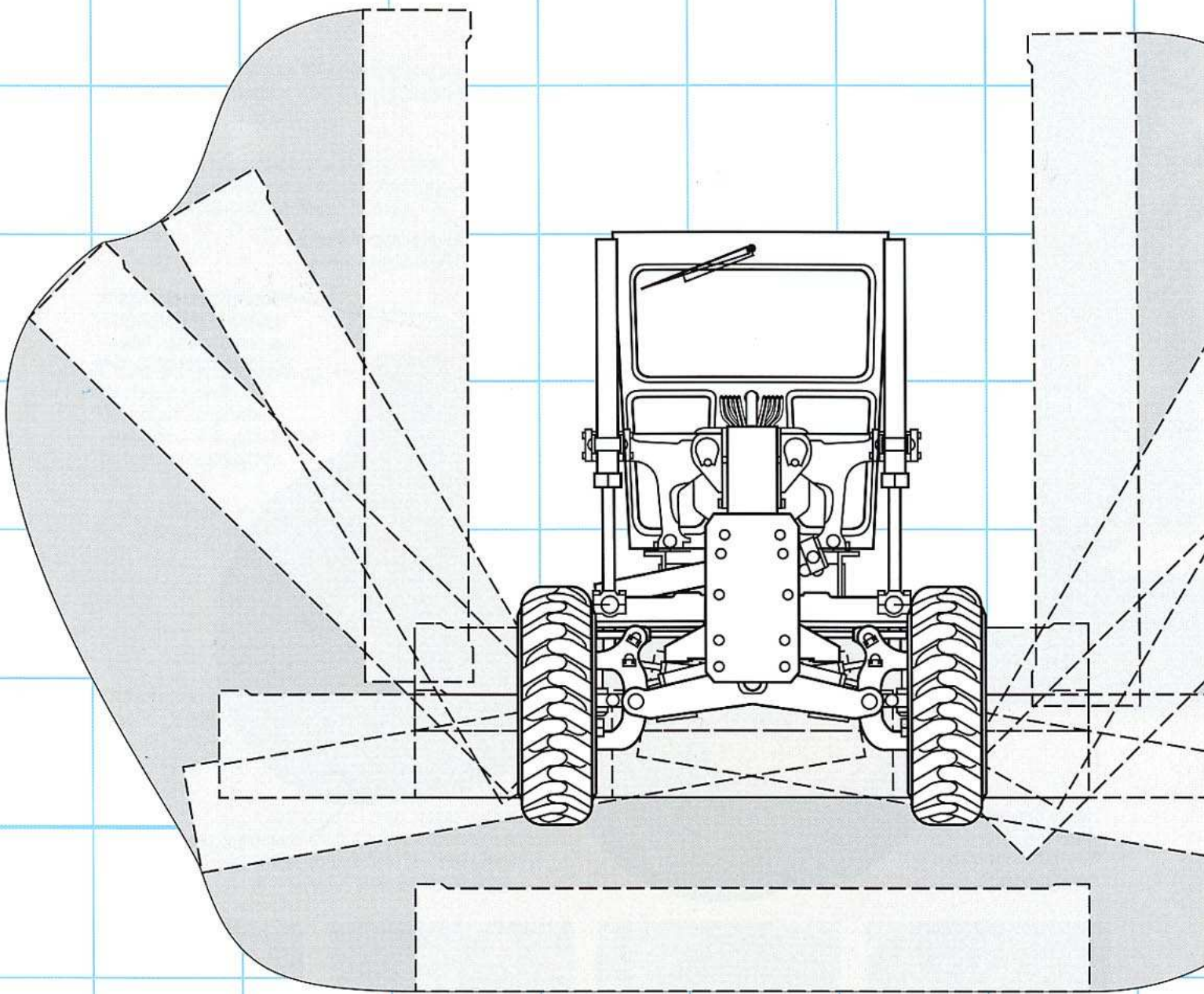

**M.B.C.S.**  
**MOVEABLE BLADE CONTROL SYSTEM**  
(OPTIONAL)



# Give the job to a Champion

Series IV graders are designed to work better with you ...  
and they're equipped to do more for you.

With their all-new closed center load-sensing hydraulics, Series IV graders achieve a new level of precision and responsiveness for fine grading control. The system senses the load requirement of the hydraulic functions, including steering, and maintains the system pressure 250 psi (17,25 Bar) above the load.

*The main hydraulic/steering pump is a load-sensing gear-type pump chosen for extended service life and low replacement cost. Gear type pumps are more tolerant of fluid contamination, perform better in cold weather, and are easier to service than piston pump designs.*

When hydraulic power is not required, standby pressure is held at just 90 psi (6,2 Bar), to improve fuel-efficiency and reduce heat. Valve spool metering ensures precise blade control, while the variable flow pump maintains consistent hydraulic speed at all engine RPMs and in multiple function operations.

*Foot-pedal operated full-oil clutch provides superior "inching" capability and precise control in tight working conditions.*



Series IV also introduces a new optional Moveable Blade Control System providing the best blade mobility in the business. Its 7 positions provide extended reach for ditch cutting, bank sloping and shoulder work. The blade lift arms have been sculptured to provide the best visibility to the work area. The operator can set up 2:1 bank sloping and a 90° blade position to the left and right without leaving the cab!

The blade lift system geometry features parallel lift cylinders with the widest stance in the industry. This wide positioning minimizes end-to-end blade interaction. The side shift cylinder is designed to operate closer to horizontal than with any other lift system; the operator can maintain grade more easily when adjusting both blade lift cylinders. The total system provides maximum stability in both heavy grading and high speed road maintenance, plus precise control for fine grading applications.

*With its 72° front axle steering arc, Series IV moves comfortably in confined work areas. The tight turning radius means faster finishing in cul-de-sacs and less following-up in the corners.*

*A long blade base maintains maximum blade down pressure – the grader can cut more material in each pass to achieve higher productivity while retaining steering control.*



740  740A

**SPECIFICATIONS:**



**OPERATING WEIGHT  
(Standard Equipment)**

Weights shown include full cab with ROPS, all operating fluids and operator.

Total ..... 35,100 lbs. (15 921 kg)  
On front wheels ..... 10,430 lbs. (4 731 kg)  
On rear wheels ..... 24,670 lbs. (11 190 kg)

Weight adjustments for various options are listed.

**Typically equipped operating weight:** Includes 14.00 x 24, 12 pr., G2 tires on 10" (254 mm) rims, and 14' x 29' x 1" (4 267 mm x 737 mm x 25 mm) moldboard and Moveable Blade Control System.  
- with Scarifier ..... 38,060 lbs. (17 264 kg)  
- with rear-mounted Ripper-Scarifier and front-mounted Push Block ..... 39,310 lbs. (17 831 kg)



**PRODUCTIVITIES  
(Standard Equipment)**

Maximum blade pull (no wheel slip) ..... 22,203 lbs. (10 071 kg)  
Blade down pressure - cutting capability (ISO 7134) ..... 18,459 lbs. (8 373 kg)  
- compaction capability ..... 19,148 lbs. (8 686 kg)  
Blade down pressure is the maximum downward force which may be applied at the cutting edge.



**ENGINE DATA**

Make/Model ..... Cummins LT-10-C  
Type ..... 4 Cycle, Turbocharged  
No. of cylinders ..... In Line 6  
Bore & stroke .. 4.921 x 5.354 in. (125 x 136 mm)  
Displacement ..... 611 cu. in. (10 L)  
Rated gross brake horsepower @ 2100 RPM ..... 225 hp (168 kW)  
Rated net brake horsepower @ 2100 RPM ..... 210 hp (157 kW)  
Peak torque @ 1300 RPM ..... 732 lb. ft. (992 Nm)

Engine equipped with a two stage, dual element, dry-type air cleaner with evacuator and dash-mounted service indicator. 24 volt starting and electrical system with 75 amp (1800 watt) brushless alternator with internal voltage regulator. Two heavy duty 12 volt maintenance-free batteries with 900 cold cranking amps (CCA) and 160 minutes reserve capacity per battery. System includes battery disconnect.  
Performance: Rated net brake horsepower SAE standard J1349/ISO 3046-2 conditions with water pump, lubricating oil pump, fuel system, air cleaner, muffler, alternator, and cooling fan.



**TRANSMISSION**

Make/Model ..... Champion 8400  
Fully sequential, direct drive, powershift transmission. Engine can not be started if transmission is in gear. Transmission controller contains an electronic self-diagnostic feature. The flywheel-mounted, multi-disc master clutch is oil-cooled for long life.

Ground speeds at 2100 RPM with standard tires:

Forward		Reverse	
Gears	mph	Gears	km/h
1	2.5	1	2.5
2	3.6	2	4.0
3	4.9	3	7.9
4	6.7	4	10.8
5	9.7	5	15.6
6	13.6	6	21.9
7	18.9	7	30.4
8	26.3	8	42.3

Transmission guard is standard equipment and is hinged for easy access.



**DIFFERENTIAL / FINAL DRIVE**

Make/Model ..... Champion SR40  
Single reduction final drive with an operator controlled lock/unlock differential. Rear axles are case hardened, full floating design, supported on double row spherical roller bearings.



**TANDEMS**

Oil-tight, oscillating tandem case has internal gusseting for maximum torsional strength. Field proven split ring/flanged sleeve tandem mounting and 1" thick inner wall resists flexing from side loading during severe applications. Drive chain sized for long life.

Depth ..... 24.5" (622 mm)  
Width ..... 8.25" (210 mm)  
Thickness - inner wall ..... 1.0" (25 mm)  
                  - outer wall ..... 0.75" (19 mm)  
Center distance ..... 61.5" (1 562 mm)  
Drive chain pitch ..... 2.0" (51 mm)  
Oscillation ..... ±15°



**BRAKES**

Service Brakes: Foot Operated  
Fade resistant, hydraulically actuated, oil disc service brakes located at the four (4) tandem drive wheels are self-adjusting, fully sealed and maintenance-free. System features cross-over dual braking circuits for even braking on both sides of the grader. Includes reserve power assist and operator warning system (visual and audible).

Parking Brake: Hand Operated  
Independent, disc-type hand brake on transmission output shaft and effective on all four (4) tandem drive wheels. Includes visual and audible operator warning system for parking brake on, transmission in gear condition.

Braking systems to: SAE Recommended Practice J1473 OCT. 90, and J1152 APR. 80; ISO 3450-1993-01-28. Champion uses asbestos-free brake components.



**WHEELS & TIRES  
(Standard Equipment)**

Tire size ..... 14.00 x 24, G-2  
Ply rating (pr.) ..... 12  
Rim size ..... 8.0" (203 mm)  
Bolt-on rims are interchangeable front and rear.



**FRONT AXLE**

Type ..... Fully welded steel truss, gusseted for torsional strength oscillates on a single 3.5" (89 mm) diameter centre pivot pin  
Wheel lean ..... 18° R & L  
Oscillation ..... 16° up and down  
Ground clearance ..... 24.0" (610 mm)  
Twin 3" (76 mm) diameter wheel lean cylinders with lock valve is standard equipment.



**STEERING**

Hydraulic power front wheel steering incorporating two steering cylinders. Meets SAE J1511 OCT. 90.  
Minimum turning radius using front axle steering, wheel lean and unlocked differential:  
740 conventional or straight frame ..... 35'1" (10 693 mm)  
740A articulated frame ..... 25'7" (7 798 mm)  
Steering arc ..... 72°  
Frame articulation angle 740A ..... 22°  
Articulation lock standard.



**FRAME**

Full front and rear frame sections. First user life-time frame warranty.

**Front:** Fully welded box section. Double-lapped in high load areas. Lowered nose plate on front frame provides the best visibility in the industry to the front of the grader.

Minimum dimensions of box section ..... 10.0" x 12.0" (254 mm x 305 mm)  
Plate thickness ..... 0.75" (19 mm)  
Vertical section modulus at arch ..... 141 cu.in. (2 311 cm³)  
Linear weight - average ..... 154 lbs/ft (229 kg/m)

**Rear:** Full rear frame permits modular powertrain mounting for ease of service and simplifies attachment mounting.

Minimum dimensions of rear frame ..... 4.0" x 11.0" (102 mm x 279 mm)  
Plate thickness ..... 1.0" (25 mm)

Choice of conventional (rigid) or articulated frames:  
740 ..... Conventional  
740A ..... Articulates behind cab.  
Twin 5" (127 mm) hydraulic cylinders articulate frame 22° right and left. Anti-drift lock valve ensures stable operation.



**CIRCLE**

Hardened teeth, cut on outside of circle for maximum leverage and minimum wear. Circle is machined after welding to ensure flatness. The circle is held positively in place at six points by three adjustable clamp plates and three adjustable guide shoes providing optimum circle support and load distribution. The primary set of clamps and guide shoes is located at the front of the circle where greatest loading occurs. DURAMIDE-faced clamp and guide shoes prevent metal to metal contact. DURAMIDE is a synthetic material that extends service life and reduces maintenance requirements.

Diameter ..... 66.25" (1 683 mm)  
Thickness ..... 1.25" (32 mm)  
Adjustable guide shoes ..... 3  
Adjustable clamp plates ..... 3



**CIRCLE DRIVE**

Champion's patented dual cylinder circle drive system uses direct-acting hydraulic power for exceptional turning and holding capability under full load. Circle drive system is fully protected against impact damage by an overload cushion valve as standard equipment.

Hydraulic drive cylinders ..... 2  
Points of leverage ..... 2  
Rotation ..... 360° continuous



**DRAWBAR**

Fully welded box section. Narrow 'T' design permits optimum visibility to the work area. Drawbar connection provides an adjustment to compensate for different tire sizes. Blade lift cylinder anchors are straddle-mounted on drawbar to provide maximum strength and support.

Dimensions of box section ..... 6.5" x 6.5" (165 mm x 165 mm)  
Plate thickness ..... 1.0" & 0.75" (25 mm & 19 mm)



### MOLDBOARD

Standard moldboard with replaceable end bits ..... 12' x 29" x 1" (3 658 mm x 737 mm x 25 mm)  
 Blade material ..... SAE 1050 high carbon steel  
 Edge: through hardened ..... 6" x 5/8" (152 mm x 16 mm) boron steel  
 Drilling - Bolt diameter ..... 6" drilling - 5/8" bolts  
 Slide rails supported with DURAMIDE bearings.

### BLADE RANGE: FIXED POINT LIFT SYSTEM (Standard)

(Dimensions shown with standard moldboard)  
 Reach outside tires  
 - straight frame ..... 75.0"(1 905 mm)  
 Reach outside tires  
 - articulated frame ..... 116.0"(2 946 mm)  
 Blade slide ..... 53.5"(1 359 mm)  
 Circle side shift ..... 20.0" (508 mm)  
 Blade ground clearance ..... 17.25" (438 mm)  
 Blade cutting depth ..... 25.0" (635 mm)  
 Blade tilt range ..... 48° forward; 2.5° back  
 Number of moldboard tilt cylinders ..... 2  
 Bank sloping angle ..... 90°

### BLADE RANGE: MOVEABLE BLADE CONTROL SYSTEM (Optional)

(Dimensions shown with standard moldboard)

	LEFT	RIGHT
Reach outside tires - straight frame	76.0"(1 930 mm)	73.5"(1 867 mm)
Reach outside tires - articulated frame	117.0"(2 973 mm)	113.0"(2 870 mm)
Blade slide	26.5" (673 mm)	26.5" (673 mm)
Circle side shift	26.0" (660 mm)	24.0" (610 mm)
Maximum bank sloping angle	90°	90°

Blade ground clearance ..... 17.0" (432 mm)  
 Blade cutting depth ..... 30.0" (762 mm)  
 Blade tilt range ..... 48° forward 2.5° back



### CAB & CONTROLS

Operator noise exposure is limited to 82 dB(A) per SAE J919 JUNE 86 (enclosed cab). Located in the pedestal head is the engine oil pressure, coolant temperature and fuel level gauges and a three-level electronic monitoring system. Pedestal located switches include: differential lock/unlock, independent moldboard floats (optional) and combination turn signal, hazard lights, and high beam headlight switch. Heater and wiper/washer controls, lighting and accessory switches are grouped in the operator's right hand console. This console also contains the ignition key and access to the circuit breaker panel. An accelerator/decelerator foot pedal and slider type hand throttle are standard equipment. Cab door opening and closing is easy from either a seated position or while entering and exiting. Fixed front window enhances visibility by reducing window frame width.

### Full Height Cab with ROPS INSIDE DIMENSIONS:

Height ..... 74.0"(1 880 mm)  
 Width @ controls ..... 56.0"(1 422 mm)  
 Depth @ controls ..... 55.5"(1 410 mm)

An optional Low Profile Cab is available with an inside height of 62" (1 575 mm). All Champion cabs and canopies are designed to meet or exceed SAE J1040 APR. 88, ISO 3471/1-1986(E), and 86/295/EEC ROPS requirements. The seat belt is 3" (76 mm) wide and meets SAE J386 JUNE 93; ISO 6683-1981(E). A cushioned vinyl covered bucket seat with fore & aft and height adjustment is standard.



### LOAD SENSING HYDRAULICS

Closed center hydraulic system senses load requirements and maintains system pressure 250 psi (17,25 Bar) above the load.

When hydraulic pressure is not required, system pressure is only 90 psi (6,2 Bar). Low standby pressure improves fuel-efficiency and reduces heat generation.

System incorporates lock valves to prevent cylinder drift under load in the following circuits: blade lift, moldboard tilt, circle shift, wheel lean, articulation and scarifier. All hoses and fittings are equipped with 'O' ring seals to eliminate leaks.

Pump design features include cast iron end covers and center housing, and a one-piece gear and shaft assembly to ensure reliability and a service life exceeding that of most piston pumps.

Maximum pressure ..... 2,500 psi (172 Bar)  
 Output at 2100 RPM ..... 0-48.2 gpm (0-182 lpm)  
 Filtration ..... 7 micron spin-on type



### CAPACITIES

	U.S. Gal.	Imp. Gal.	Litres
Fuel Tank	100.0	83.3	378,5
Transmission	10.2	8.5	38,8
Final drive	6.0	5.0	23,0
Tandems (ea.)	26.4	22.0	100,0
Hydraulic oil tank	23.8	19.8	90,0
Coolant Antifreeze protection to -58° F (-50° C)	10.8	9.0	40,8
Engine oil	10.3	8.6	39,0

### STANDARD FEATURES:

- Operator controlled, lock/unlock differential final drive
- 4-wheel, cross-over, dual braking system with reserve power assist
- Ratchet-type park brake with operator warning alarm and indicator
- Fully-sequential, powershift 8400 transmission, with guard
- 13.5" diameter, 4-plate, full oil clutch for operator control
- Choice of rigid or articulating frames
- Full front and rear frame sections designed to absorb shock loading of attachment use
- First user lifetime frame warranty
- Cushion valve circle drive protection to minimize impact damage
- Hardened circle teeth cut on outside of circle for maximum wear resistance
- Isolation-mounted cab, transmission and engine for reduced noise and vibration
- Adjustable steering pedestal with tilt head for maximum operator comfort
- Gauges include: coolant temperature, engine oil pressure, fuel, hourmeter, dash-mounted air cleaner service indicator, articulation angle indicator, three-level electronic monitoring system - M4 - with visual and audible warnings
- Load-sensing, closed-center hydraulic system with short-throw, low effort control levers, positioned in the industry-accepted arrangement. Hydraulically operated blade lift, circle turn, moldboard slide and tilt, circle shift and wheel lean functions.

- 100 gallon fuel capacity
- Horn
- Hinged radiator guard for easy trash clean out. Engine compartment fan guard included.
- Back-up alarm with automatic volume level
- Painted Champion Yellow
- Lockable tool box with storage space for scarifier shanks

### OPTIONAL EQUIPMENT (May vary)

	lbs.	kg
Accumulators - blade lift	130	59
- circle side shift	65	29
Air conditioner - 21,500 BTU - HFC-134a (non-CFC refrigerant) with cab pressurizer/filter	130	59
Battery warmer	5	2
Brush guards	40	18
Cab		
- canopy shell with ROPS - deduct ....	(200)	(91)
- low profile cab with ROPS - deduct (200)	(200)	(91)
Cab heater - 49,000 BTU	30	14
Cab pressurizer/filter	14	6
Defroster fan	3	1
Engine block heater	3	1
Engine precleaner - Turbo II	6	3
Engine side panels	50	23
Ether cold start	10	4
Exhaust rain cap	-	-
Fan - blower type (suction type is standard)	-	-
Float control - Right and Left independent, electric	15	7
Hub odometer	-	-
Hydraulic tank heater	3	1
Jack - 20 ton (18.5 tonne)	35	16
Lights		
- back-up lights - 2	-	-
- beacon (amber or blue)	4	2
- clearance lights front & rear	2	1
- direction signals	-	-
- front-mounted plow lights - 2		
- high	120	54
- low	100	45
- Headlights with dimmer switch	-	-
- Moldboard lights - 2	2	1
- Rear flood lights - 2	2	1
- Snow wing lights - 2	2	1
Machine Monitor Plus package - M44 Audible and visual warnings for transmission and hydraulic filter restriction, low engine oil pressure, high coolant temperature, high transmission temperature, and low transmission clutch pressure	-	-
Mirrors - outside - right	2	1
- left	2	1
Moldboards		
- 13' x 29" x 1" (3 962 mm x 737 mm x 25 mm)	150	68
- 14' x 29" x 1" (4 267 mm x 737 mm x 25 mm)	300	136
Moldboard extensions R & L - 2' (610 mm)	200	91
Moldboard edges -Carbide 3/4" x 5"	-	-
Moveable Blade Control System	750	341

OPTIONAL EQUIPMENT (cont'd)	lbs.	kg		lbs.	kg		lbs.	kg
Operator convenience package - lunch box, steel vacuum bottle and holder, ash tray.....	10	5	Suspension seat .....	55	25	Tool kit.....	-	-
Paint - custom colors .....	-	-	Tie-down brackets .....	100	45	Transmission sump heater.....	-	-
Radiator shutters - hinged .....	10	4	Tires			Tropical protection .....	-	-
Reflectors - rear.....	-	-	- 14.00 x 24, 12 pr., G2, 10" (254 mm) rims .....	360	161	Vandalism protection .....	8	4
Remote valve for attachments - 3 or 5 bank - remote mount .....	25	11	- 17.5 x 25, 12 pr., G2, 14" (356 mm) rims .....	942	428	Wheel weights front or rear - each .....	250	113
Supplemental steering (power assisted) meets SAE J53 OCT. 84 .....	61	28	- 16.00 x 24, 12 pr., G2, 10" (254 mm) rims .....	1,452	659	Window - opening - lower front.....	-	-
			Tire chains - pair.....	300	136	Window - opening sliders - left/right .....	-	-
						Wiper and washer - front .....	-	-
						Wiper and washer - rear .....	-	-
						Wiper and washer - lower front windows....	-	-

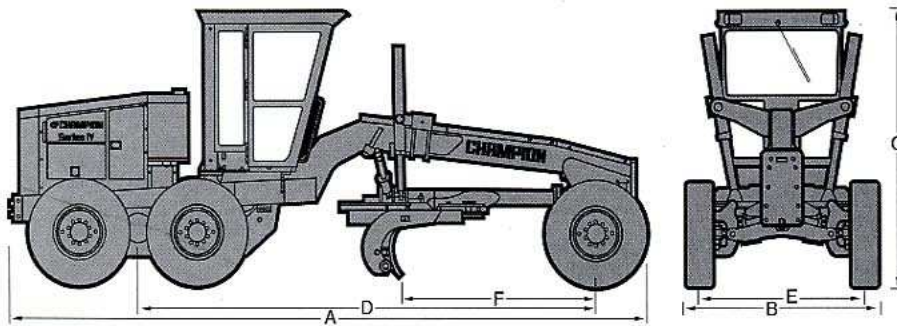

**DIMENSIONS**

A Overall length.....	28'4" (8 636 mm)
B Overall width.....	8'4" (2 540 mm)
C Overall height with cab.....	11'2" (3 404 mm)
- with Low Profile Cab.....	10'2" (3 099 mm)
D Wheelbase	
- 740 .....	20'6" (6 248 mm)
- 740A.....	20'6" (6 248 mm)
E Tread width.....	7'0" (2 136 mm)
F Blade base	
- ISO 7134 .....	8'11" (2 718 mm)
- compaction.....	9'4" (2 845 mm)

**CHAMPION MATCHED ATTACHMENTS**

A-Frame.....	850 lbs. (386 kg)	Push block .....	700 lbs. (318 kg)	V plow	
Dozer blade		Ripper-scarifier, rear.....	2,100 lbs. (953 kg)	- 9' (2 743 mm).....	2,560 lbs. (1 161 kg)
- 8' (2 438 mm).....	1,600 lbs. (726 kg)	Scarifier, front.....	1,550 lbs. (703 kg)	- 10' (3 048 mm).....	2,720 lbs. (1 234 kg)
- 9' (2 743 mm).....	1,650 lbs. (749 kg)	Snow wing		Windrow eliminator.....	1,300 lbs. (590 kg)
One-way plow.....	2,350 lbs. (1 067 kg)	- front-mounted.....	2,900 lbs. (1 317 kg)		
		- rear-mounted .....	3,100 lbs. (1 407 kg)		

Specifications subject to change without notice. Some items included in this brochure are optional.  
 DURAMIDE is a registered trademark of Champion Road Machinery Limited.  
 Your safety and the safety of those around you depends on using care and judgement when operating and servicing your grader. Do not operate the grader until you read and understand the warnings and instructions in the operator's manual.



CANADA  
 Goderich, Ont.

© 1994 Champion Road Machinery Limited