

ZAXIS

16

18

25



HYDRAULIC EXCAVATOR

- **Model Code:** ZX16 / ZX18 / ZX25
- **Engine Rated Power:** 8.8 kW (11.8 HP) / 8.8 kW (11.8 HP) / 13.7 kW (18.4 HP)
- **Operating Weight:** 1 590 - 1 720 kg / 1 710 - 1 840 kg / 2 450 - 2 580 kg
- **Backhoe Bucket:** (ISO Heaped) : 0.02 - 0.05 m³ / 0.02 - 0.05 m³ / 0.04 - 0.085 m³

THE HITACHI MINI EXCAVATORS: DESIGNED FROM



EXPERIENCE



Based on Japanese philosophy, Hitachi has developed a new series of mini excavators for the European market. These excavators have been specially tailored for the specific requirements that European customers place on Hitachi products. For example, the design has been both renewed and perfected, the operator cabins are more spacious and all components are easier to access. These excavators are all powered by Shibaura engines and have the trusted Japanese quality that you have come to expect from Hitachi.

The new mini excavators excel in working range and lifting capacity. In addition to this a maximum quantity of identical components as possible have been used to guarantee exchangeability of the parts and to keep maintenance costs low.

High regard for the environment was taken when designing the new excavators. The wiring is lead-free, no asbestos is used in the excavators and a large number of recyclable parts are used, which is completely in line with the ISO 14001 requirements. Furthermore, the ZAXIS16/18/25 also has both an aluminium radiator and oil cooler, which are extra environmentally friendly.

DESIGNED FOR COMFORT



Cabin

Europeans are innately longer than Asians. Therefore, it is logical that the operator's cabin of excavators for the European market differs from those for the Asian market. In line with this we have made the European operator's cabin more spacious and given it a more luxurious finish.

The inside of the cabin is well insulated; giving it a low noise level and the neatly fitted heating gives extra comfort during cold weather. The cabin and the canopy on four pillars are TOPS and FOPS tested to guarantee the safety of the operator. For extra safety a seatbelt is fitted and an evacuation hammer is present in the operator's cabin.



For the added comfort of the operator the sprung seat can be widely adjusted and is easy to reach by means of a wide entrance.

The ease of operation has been increased due to the fitting of new control levers, whereby the arms are supported by an arm support. An extra window on the bottom right side has further optimised the view of the operator and the front screen can be fully moved upwards and locked in place. The canopy, which has the same dimensions as the operator's cabin, is fitted with a rear window.



The operator's cabin is prepared for a radio connection with the antenna fitted on the outside and enough room inside for two loudspeaker cabinets, which are easy to connect.



DESIGNED FOR POWER



Frame

The mini excavators are provided with a swing boom, which is specially suited for accurate work such as digging along walls. The hoses of the bucket cylinder of the Hitachi mini excavators run through the arm, which gives them better protection against external damage.

Each track is driven by a high-torque axial piston engine providing the excavator with a large pulling force at both high and low speeds.

Engine

The Hitachi mini excavators are equipped with environmentally-friendly, low-emission engines from Shibaura. These engines have been developed according to the latest standards for diesel engines and have an exceptionally low fuel consumption. They are also considered to have an extremely high record of reliability. The mounting of the engine, the engine hood and the exhaust are designed so that they produce as little noise as possible for improved working comfort.



DESIGNED FOR QUALITY



Hydraulic system

The Hitachi mini excavators are provided with a new hydraulic system, including a circuit that regenerates the hydraulic energy, which greatly improves the efficiency. The system works with three pumps - two variable piston pumps and a gear pump. The two variable pumps provide optimum oil flow to the main functions; the gear pump provides oil for the swing circuit, the blade and the swing boom. This makes it possible to operate the excavator very accurately and allows fast and smooth combined movements to be made, including the driving.

The travel levers of the excavators are now also hydraulically controlled. This makes the operation both lighter and more accurate. If long distances have to be driven, pedals can be used.



The left console and safety lever can be pivoted far to the cabin rear. This improves accessibility to the cabin entrance. The safety lever prevents the excavator from unexpectedly operating if the handles are accidentally touched when the operator sits down.

The mini excavators are provided standard with two extra hoses that go through to the arm. Optional equipment such as a crusher can be connected to these. The hydraulic oil flow can be simply diverted with the P.T.O. valve.



The hydraulic extended undercarriage of the ZAXIS18 has been improved, and the stability has increased. By means of an electrical switch, you can switch over from the operation of the extendable blade to the span of the undercarriage. The blade can be manually extended to the same width as the undercarriage.



DESIGNED FOR EFFICIENCY

Maintenance

The maintenance of the new series of mini excavators has been simplified, partly because of the large engine hood that can be opened widely. As a result, it is possible to inspect components quickly, easily and effectively and if necessary to repair them. With the ZAXIS25, the hydraulic oil level can be easily read on the side of the excavator.

The main valve block is placed under the easily opened floor plate in the operator's cabin and can also be accessed on the side.

The fuel tank is maintenance free, as it is made of plastic, so there is no chance of corrosion. In addition to this a water separator is fitted as standard in the fuel system so that no water can enter the system.

An air filter indicator indicates when the air filter needs to be replaced, it is very easy to change.

Furthermore, the pivots in the boom are fitted with Hitachi HN self-lubricating bushings, and as a result less maintenance is required. The HN bushings only need to be lubricated after 500 hours of operation.



Engine

Model	Shibaura E673L-C
Type	Water-cooled, 4-cycle, 3-cylinder swirl chamber type diesel engine
Rated flywheel power	8.7 kW (11.9 PS)
DIN 6271, net	at 2 300 min ⁻¹ (rpm)
Rated flywheel power	8.8 kW (11.8 HP)
SAE J1349, net	at 2 300 min ⁻¹ (rpm)
Maximum torque	38.8 Nm (3.96 kgf/m)
	at 1 700 min ⁻¹ (rpm)
Piston displacement	0.761 l
Bore and stroke	67 mm x 72 mm
Battery	1 x 12 V, 36 Ah

Hydraulic system

The Optimum Hydraulic System (OHS) uses three pumps for job efficiency and smooth combined operations.

Main pumps	Two variable displacement axial piston pumps
Maximum oil flow	2 x 16.1 l/min
Third pump	One gear pump
Maximum oil flow	10.4 l/min
Pilot pump	One gear pump
Maximum oil flow	6.2 l/min

RELIEF VALVE SETTINGS

Implement circuit	20.6 MPa (210 kgf/cm ²)
Swing circuit	12.3 MPa (125 kgf/cm ²)
Travel circuit	20.6 MPa (210 kgf/cm ²)
Pilot circuit	3.9 MPa (40 kgf/cm ²)

HYDRAULIC CYLINDERS

High-strength piston rods and tubes. Cylinder cushion mechanisms provided in boom raise circuit to absorb shocks at stroke ends.

DIMENSIONS

	Qty.	Bore	Rod dia.	Stroke
Boom	1	55 mm	30 mm	427 mm
Arm	1	55 mm	30 mm	420 mm
Bucket	1	50 mm	30 mm	311 mm
Boom swing	1	60 mm	30 mm	358 mm
Blade	1	65 mm	35 mm	97 mm
Span*	1	50 mm	30 mm	310mm

*Only ZX18

Controls

Hydraulic pilot control levers for boom, arm, bucket, swing and travel. Mechanical linkage control levers for boom swing, blade/track width* and hydraulic PTO.

*Only ZX18

Swing mechanism

High-torque, orbit motor. Swing circle is single-row, shear-type ball bearing with induction-hardened internal gear. Internal gear and pinion are immersed in lubricant. Swing parking brake is spring-set/hydraulic-released disc type. Swing shockless valve built in swing motor absorbs shocks when stopping swing, ensuring smooth stops.
Swing speed 9.1 min⁻¹ (9.1 rpm)

Undercarriage

TRACKS

Tractor-type undercarriage. Welded track frame using carefully selected materials. Side frame extended by span cylinder*.

*Only ZX18

NUMBERS OF ROLLERS ON EACH SIDE

Upper guide plate	
ZX16	1
ZX18	2
Lower rollers	3

TRACTION DEVICE

Each track driven by a high-torque, 2-speed axial piston motor through planetary reduction gear, allowing counter-rotation of the tracks.

Travel speeds (rubber shoes)	High: 0 - 4.0 km/h Low: 0 - 2.0 km/h
Travel speeds (grouser shoes)	High: 0 - 4.0 km/h Low: 0 - 2.0 km/h
Gradeability	30° (58%) continuous

Weights and ground pressure

ZX16

Equipped with 0.93 m arm and 0.044 m³ (PCSA heaped) bucket.

	Operating weight	Ground pressure
4-Pillar canopy version		
230 mm rubber shoes	1 590 kg	27 kPa (0.28 kgf/cm ²)
230 mm grouser shoes	1 650 kg	28 kPa (0.29 kgf/cm ²)
Cabin version		
230 mm rubber shoes	1 660 kg	28 kPa (0.29 kgf/cm ²)
230 mm grouser shoes	1 720 kg	29 kPa (0.30 kgf/cm ²)

ZX18

Equipped with 0.93 m arm and 0.044 m³ (PCSA heaped) bucket.

	Operating weight	Ground pressure
4-Pillar canopy version		
230 mm rubber shoes	1 710 kg	29 kPa (0.30 kgf/cm ²)
230 mm grouser shoes	1 770 kg	30 kPa (0.31 kgf/cm ²)
Cabin version		
230 mm rubber shoes	1 780 kg	30 kPa (0.31 kgf/cm ²)
230 mm grouser shoes	1 840 kg	31 kPa (0.32 kgf/cm ²)

Front-end attachments

BACKHOE BUCKETS

ISO 7451 capacity	Width		No. of teeth	Weight	Use	
	Without side cutters	With side cutters			0.93 m Short arm	1.13 m Long arm
0.02 m ³	225 mm	250 mm	2	25 kg	A	A
0.035 m ³	325 mm	350 mm	3	29 kg	A	A
0.04 m ³	385 mm	410 mm	3	31 kg	A	A
0.044 m ³	425 mm	450 mm	3	32 kg	A	B
0.05 m ³	475 mm	500 mm	4	36 kg	B	C
Arm crowd force					8.9 kN (910 kgf)	8.1 kN (820 kgf)
Bucket digging force					13.5 kN (1 380 kgf)	

A: General digging B: Light-duty digging C: Loading

Boom swing angle Left 70°, Right 50°

Dimensions

The 4-pillar canopy or cabin can be mounted on the upper structure according to job needs and applicable regulations.

The 4-pillar canopy and cabin conform to TOPS (ISO 12117) and FOPS (ISO 10262, Level I) requirements.

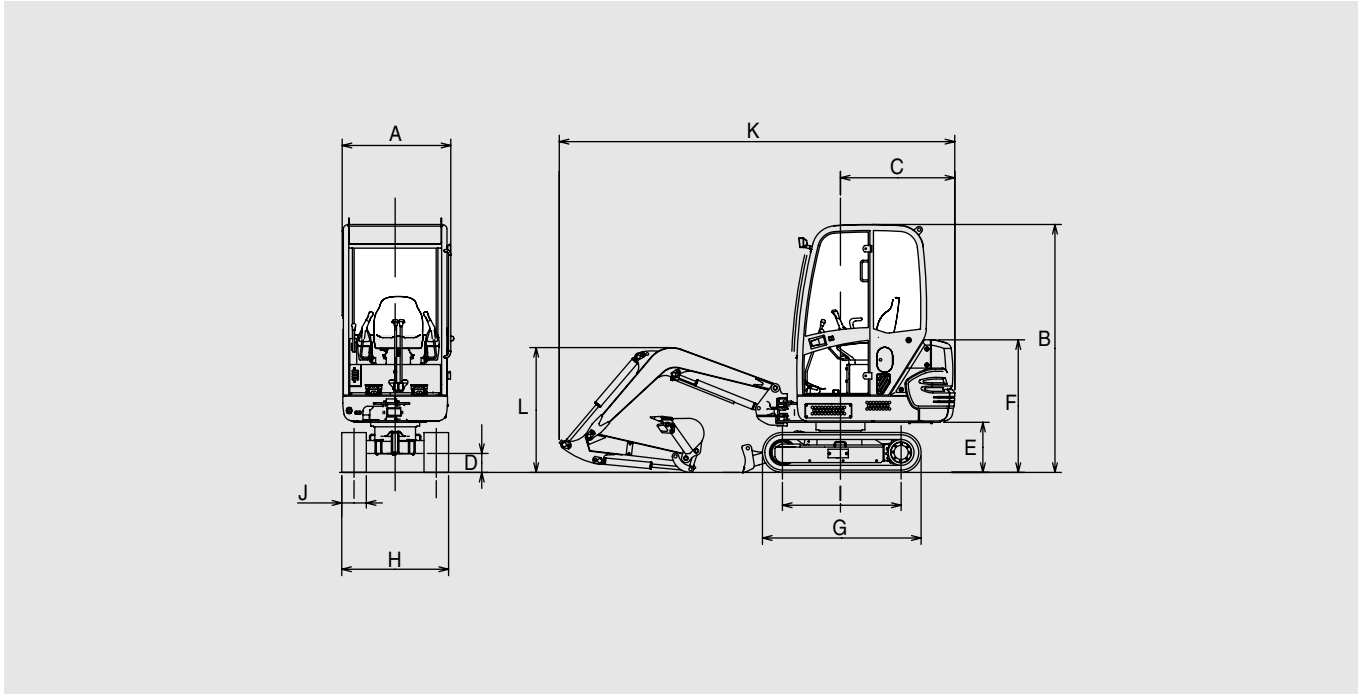

ZX16

Notes:

1. The illustration shows the cabin version equipped with 230 mm rubber shoes.
2. Values are identical for cabin and canopy versions.

Unit: mm

	ZX16
A Overall width	1 050
B Canopy / Cabin height	2 280
C Rear-end swing radius	1 070
D Minimum ground clearance	235
E Counterweight clearance	435
F Engine cover height	1 210
G Undercarriage length	1 470
H Undercarriage width	1 000
I Sprocket centre to idler centre	1 110
J Track shoe width	230
K Maximum transport length	3 690
L Overall height of boom	1 150

ZX18

Notes:

1. The illustration shows the cabin version equipped with 230 mm rubber shoes.
2. Values are identical to the cabin and canopy versions.

Unit: mm

	ZX18
A Overall width	1 050
B Canopy / Cabin height	2 310
C Rear-end swing radius	1 070
D Minimum ground clearance	175
E Counterweight clearance	470
F Engine cover height	1 240
G Undercarriage length	1 470
H Undercarriage width extended / retracted	1 300 / 1 000
I Sprocket centre to idler centre	1 110
J Track shoe width	230
K Maximum transport length	3 690
L Overall height of boom	1 150

Working ranges

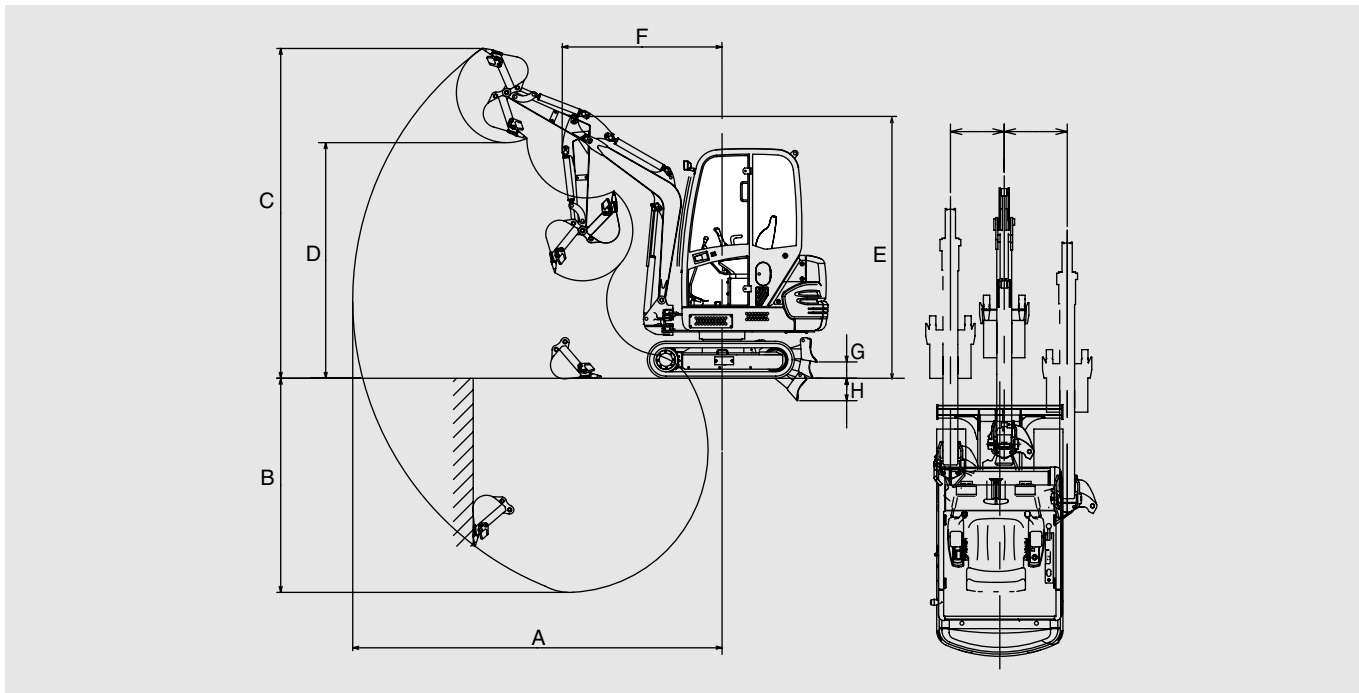

ZX16

- Notes:
1. The illustration shows the cabin version equipped with 0.044 m³ bucket, 0.93 m arm and 230 mm rubber shoes.
 2. Values are identical for cabin and canopy versions.

Unit: mm

	ZX16 Canopy & Cabin	
	0.93 m arm	1.13 m arm
A Maximum digging reach	3 740	3 920
B Maximum digging depth	2 200	2 400
C Maximum cutting height	3 300	3 390
D Maximum dumping height	2 350	2 440
E Transport height	2 640	2 640
F Minimum swing radius	1 620	1 660
G Blade bottom highest position (above ground level)	170	170
H Blade bottom lowest position (below ground level)	220	220
Maximum boom-swing angle	L70° / R50°	L70° / R50°
Offset distance	L490 / R400	L490 / R400

ZX18

- Notes:
1. The illustration shows the cabin version equipped with 0.044 m³ bucket, 0.93 m arm and 230 mm rubber shoes.
 2. Values are identical for cabin and canopy versions.

Unit: mm

	ZX18 Canopy & Cabin	
	0.93 m arm	1.13 m arm
A Maximum digging reach	3 740	3 920
B Maximum digging depth	2 200	2 400
C Maximum cutting height	3 300	3 390
D Maximum dumping height	2 350	2 440
E Transport height	2 640	2 640
F Minimum swing radius	1 620	1 660
G Blade bottom highest position (above ground level)	170	170
H Blade bottom lowest position (below ground level)	220	220
Maximum boom-swing angle	L70° / R50°	L70° / R50°
Offset distance	L490 / R400	L490 / R400

Metric measure

(Equipped with cabin)

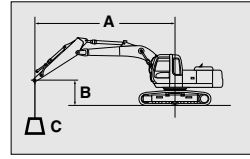

A: Load radius
B: Load point height
C: Lifting capacity

ZX16 WITH BLADE ABOVE GROUND



Rating over-side or 360 degrees



Rating over-front

Unit: kN

Conditions	Load point height	Load radius				At max. reach		
		2 m		3 m		meter		
Arm 0.93 m	2 m			2.60	1.95	2.18	1.62	3.36
Bucket 0.044 m ³	1 m	4.67	3.43	2.53	1.87	1.90	1.40	3.59
Rubber shoes 230 mm	0 m	4.37	3.17	2.43	1.78	2.01	1.47	3.41
	-1 m	4.38	3.18			2.81	2.07	2.73

ZX16 WITH BLADE ON GROUND

Unit: kN

Conditions	Load point height	Load radius				At max. reach		
		2 m		3 m		meter		
Arm 0.93 m	2 m			*2.62	1.95	*2.50	1.62	3.36
Bucket 0.044 m ³	1 m	*4.80	3.43	*2.98	1.87	*2.64	1.40	3.59
Rubber shoes 230 mm	0 m	*6.28	3.17	*3.43	1.78	*2.79	1.47	3.41
	-1 m	*5.24	3.18			*2.73	2.07	2.73

ZX16 WITH BLADE ABOVE GROUND

Unit: kN

Conditions	Load point height	Load radius				At max. reach		
		2 m		3 m		meter		
Arm 1.13 m	2 m			*2.28	1.97	1.99	1.47	3.56
Bucket 0.044 m ³	1 m	*4.14	3.50	2.54	1.88	1.76	1.28	3.77
Rubber shoes 230 mm	0 m	4.38	3.17	2.42	1.78	1.84	1.34	3.61
	-1 m	4.34	3.14	2.39	1.75	2.44	1.78	2.99

ZX16 WITH BLADE ON GROUND

Unit: kN

Conditions	Load point height	Load radius				At max. reach		
		2 m		3 m		meter		
Arm 1.13 m	2 m			*2.28	1.97	*2.28	1.47	3.56
Bucket 0.044 m ³	1 m	*4.14	3.50	*2.77	1.88	*2.42	1.28	3.77
Rubber shoes 230 mm	0 m	*6.20	3.17	*3.36	1.78	*2.59	1.34	3.61
	-1 m	*5.62	3.14	*3.07	1.75	*2.67	1.78	2.99

- Notes:
1. Ratings are based on ISO 10567.
 2. Lifting capacity does not exceed 75% of tipping load with the machine on firm, level ground or 87% full hydraulic capacity.
 3. The load point is a hook (not standard equipment) located on the back of the bucket.
 4. An asterisk mark (*) indicates load limited by hydraulic capacity.
 5. 0 m = Ground.

Metric measure

(Equipped with cabin)

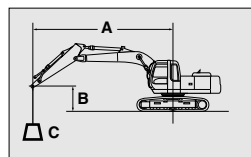

A: Load radius
B: Load point height
C: Lifting capacity

ZX18 WITH BLADE ABOVE GROUND, UNDERCARRIAGE RETRACTED 1.00 M



Rating over-side or 360 degrees



Rating over-front

Unit: kN

Conditions	Load point height	Load radius				At max. reach		
		2 m		3 m		meter		
Arm 0.93 m	2 m			*2.61	2.10	2.30	1.74	3.38
Bucket 0.044 m ³	1 m	*4.90	3.66	2.70	2.02	2.04	1.52	3.59
Rubber shoes 230 mm	0 m	4.67	3.41	2.60	1.93	2.17	1.62	3.40
	-1 m	4.68	3.43					

ZX18 WITH BLADE ON GROUND, UNDERCARRIAGE RETRACTED 1.00 M

Unit: kN

Conditions	Load point height	Load radius				At max. reach		
		2 m		3 m		meter		
Arm 0.93 m	2 m			*2.61	2.10	*2.51	1.74	3.38
Bucket 0.044 m ³	1 m	*4.90	3.66	*3.01	2.02	*2.65	1.52	3.59
Rubber shoes 230 mm	0 m	*6.27	3.41	*3.43	1.93	*2.79	1.62	3.40
	-1 m	*5.15	3.43					

ZX18 WITH BLADE ABOVE GROUND, UNDERCARRIAGE EXTENDED 1.30 M

Unit: kN

Conditions	Load point height	Load radius				At max. reach		
		2 m		3 m		meter		
Arm 0.93 m	2 m			*2.61	*2.61	*2.51	2.30	3.38
Bucket 0.044 m ³	1 m	*4.90	*4.90	2.96	2.70	2.25	2.04	3.59
Rubber shoes 230 mm	0 m	5.14	4.67	2.86	2.60	2.39	2.17	3.40
	-1 m	*5.15	4.68					

ZX18 WITH BLADE ON GROUND, UNDERCARRIAGE EXTENDED 1.30 M

Unit: kN

Conditions	Load point height	Load radius				At max. reach		
		2 m		3 m		meter		
Arm 0.93 m	2 m			*2.61	*2.61	*2.51	*2.51	3.38
Bucket 0.044 m ³	1 m	*4.90	*4.90	2.96	*3.01	2.25	2.65	3.59
Rubber shoes 230 mm	0 m	5.14	6.27	2.86	*3.43	2.39	*2.79	3.40
	-1 m	*5.15	*5.15					

- Notes:
1. Ratings are based on ISO 10567.
 2. Lifting capacity does not exceed 75% of tipping load with the machine on firm, level ground or 87% full hydraulic capacity.
 3. The load point is a hook (not standard equipment) located on the back of the bucket.
 4. An asterisk mark (*) indicates load limited by hydraulic capacity.
 5. 0 m = Ground.

Metric measure

(Equipped with cabin)

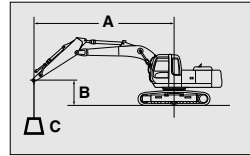

A: Load radius
B: Load point height
C: Lifting capacity

ZX18 WITH BLADE ABOVE GROUND, UNDERCARRIAGE RETRACTED 1.00 M



Rating over-side or 360 degrees



Rating over-front

Unit: kN

Conditions	Load point height	Load radius				At max. reach		
		2 m		3 m		meter		
Arm 1.13 m	2 m			*2.28	2.13	2.11	1.59	3.57
Bucket 0.044 m ³	1 m	*4.26	3.74	2.71	2.04	1.88	1.40	3.77
Rubber shoes 230 mm	0 m	4.67	3.41	2.59	1.92	1.99	1.47	3.59
	-1 m	4.64	3.39	2.57	1.90	*2.66	1.98	2.95

ZX18 WITH BLADE ON GROUND, UNDERCARRIAGE RETRACTED 1.00 M

Unit: kN

Conditions	Load point height	Load radius				At max. reach		
		2 m		3 m		meter		
Arm 1.13 m	2 m			*2.28	2.13	*2.28	1.59	3.57
Bucket 0.044 m ³	1 m	*4.26	3.74	*2.79	2.04	*2.43	1.40	3.77
Rubber shoes 230 mm	0 m	*6.21	3.41	*3.37	1.92	*2.60	1.47	3.59
	-1 m	*5.56	3.39	*3.02	1.90	*2.66	1.98	2.95

ZX18 WITH BLADE ABOVE GROUND, UNDERCARRIAGE EXTENDED 1.30 M

Unit: kN

Conditions	Load point height	Load radius				At max. reach		
		2 m		3 m		meter		
Arm 1.13 m	2 m			*2.28	*2.28	2.11	2.32	3.57
Bucket 0.044 m ³	1 m	*4.26	*4.26	2.71	2.79	1.88	2.08	3.77
Rubber shoes 230 mm	0 m	4.67	5.15	2.59	2.85	1.99	2.20	3.59
	-1 m	4.64	5.12	2.57	2.83	*2.66	*2.66	2.95

ZX18 WITH BLADE ON GROUND, UNDERCARRIAGE EXTENDED 1.30 M

Unit: kN

Conditions	Load point height	Load radius				At max. reach		
		2 m		3 m		meter		
Arm 1.13 m	2 m			*2.28	*2.28	*2.28	*2.32	3.57
Bucket 0.044 m ³	1 m	*4.26	*4.26	*2.79	*2.79	2.43	2.08	3.77
Rubber shoes 230 mm	0 m	*6.21	5.15	*3.37	2.85	2.60	*2.20	3.59
	-1 m	*5.56	5.12	*3.02	2.83	*2.66	*2.66	2.95

- Notes:
1. Ratings are based on ISO 10567.
 2. Lifting capacity does not exceed 75% of tipping load with the machine on firm, level ground or 87% full hydraulic capacity.
 3. The load point is a hook (not standard equipment) located on the back of the bucket.
 4. An asterisk mark (*) indicates load limited by hydraulic capacity.
 5. 0 m = Ground.

ZX16 Standard Equipment

Standard equipment may vary by country, so please consult your Hitachi dealer for details.

ENGINE

- Water-separator for engine fuel system

- Swing parking brake
- Hydraulic piping for breaker

HYDRAULIC SYSTEM

- Hydraulic pilot type control levers for boom, arm, bucket, swing and travel
- Mechanical linkage type control levers for boom swing, blade and hydraulic PTO
- Pilot control shut-off levers for boom, arm, bucket, swing and travel
- Two-speed travel system

CANOPY (CABIN)

- One work lamp
- Heater*
- Windshield wiper*
- Windshield washer*
- Windshield defroster*
- Evacuation hammer*
- Seat belt
- Wrist rest
- 12 V outlet

Note:* For Cabin version

UNDERCARRIAGE

- 230 mm rubber shoes
- Short stay blade

FRONT ATTACHMENTS

- 1.80 m boom
- 0.93 m arm
- 0.044 m³ hoe bucket
- O-ring type pin-seals for hoe bucket
- HN bushing

Optional Equipment

Optional equipment may vary by country, so please consult your Hitachi dealer for details.

CANOPY (CABIN)

- One work lamp

UNDERCARRIAGE

- 230 mm grouser shoes

FRONT ATTACHMENTS

- 1.13 m arm

ZX18 Standard Equipment

Standard equipment may vary by country, so please consult your Hitachi dealer for details.

ENGINE

- Water-separator for engine fuel system

- Swing parking brake
- Hydraulic piping for breaker

HYDRAULIC SYSTEM

- Hydraulic pilot type control levers for boom, arm, bucket, swing and travel
- Mechanical linkage type control levers for boom swing, blade and hydraulic PTO
- Pilot control shut-off levers for boom, arm, bucket, swing and travel
- Two-speed travel system

CANOPY (CABIN)

- One work lamp
- Heater*
- Windshield wiper*
- Windshield washer*
- Windshield defroster*
- Evacuation hammer*
- Seat belt
- Wrist rest
- 12 V outlet

Note: * For Cabin version

UNDERCARRIAGE

- 230 mm rubber shoes
- Short stay blade

FRONT ATTACHMENTS

- 1.80 m boom
- 0.93 m arm
- 0.044 m³ hoe bucket
- O-ring type pin-seals for hoe bucket
- HN bushing

Optional Equipment

Optional equipment may vary by country, so please consult your Hitachi dealer for details.

CANOPY (CABIN)

- One work lamp

UNDERCARRIAGE

- 230 mm grouser shoes

FRONT ATTACHMENTS

- 1.13 m arm

Engine

Model	Shibaura S773L-C
Type	Water-cooled, 4-cycle, 3-cylinder swirl chamber type diesel engine
Rated flywheel power	13.6 kW (18.5 PS)
DIN 6271, net	at 2 200 min ⁻¹ (rpm)
Rated flywheel power	13.7 kW (18.4 HP)
SAE J1349, net	at 2 200 min ⁻¹ (rpm)
Maximum torque	62.2 Nm (6.35 kgf/m)
	at 1 700 min ⁻¹ (rpm)
Piston displacement	1.131 l
Bore and stroke	77 mm x 81 mm
Battery	1 x 12 V, 36 Ah

Hydraulic system

The Optimum Hydraulic System (OHS) uses three pumps for job efficiency and smooth combined operations.

Main pumps	Two variable displacement axial piston pumps
Maximum oil flow	2 x 26.4 l/min
Third pump	One gear pump
Maximum oil flow	14.3 l/min
Pilot pump	One gear pump
Maximum oil flow	5.9 l/min

RELIEF VALVE SETTINGS

Implement circuit	20.6 MPa (210 kgf/cm ²)
Swing circuit	18.6 MPa (190 kgf/cm ²)
Travel circuit	20.6 MPa (210 kgf/cm ²)
Pilot circuit	3.9 MPa (40 kgf/cm ²)

HYDRAULIC CYLINDERS

High-strength piston rods and tubes. Cylinder cushion mechanisms provided in boom raise circuit to absorb shocks at stroke ends.

DIMENSIONS

	No.	Bore	Rod dia.	Stroke
Boom	1	70 mm	40 mm	547 mm
Arm	1	65 mm	35 mm	505 mm
Bucket	1	60 mm	35 mm	440 mm
Boom swing	1	75 mm	40 mm	438 mm
Blade	1	75 mm	40 mm	150 mm

Controls

Hydraulic pilot control levers for boom, arm, bucket, swing and travel. Mechanical linkage control levers for boom swing, blade and hydraulic PTO.

Swing mechanism

High-torque, axial piston motor with planetary reduction gear. Swing circle is single-row, shear-type ball bearing with induction-hardened internal gear. Internal gear and pinion are immersed in lubricant. Swing parking brake is spring-set/hydraulic-released disc type. Swing shockless valve built in swing motor absorbs shocks when stopping swing, ensuring smooth stops.
Swing speed 9.2 min⁻¹ (9.2 rpm)

Undercarriage

TRACKS

Tractor-type undercarriage. Welded track frame using carefully selected materials.

NUMBERS OF ROLLERS ON EACH SIDE

Upper guide plate	2
Lower rollers	3

TRACTION DEVICE

Each track driven by a high-torque, 2-speed axial piston motor through planetary reduction gear, allowing counter-rotation of the tracks.

Travel speeds (rubber shoes)	High: 0 - 4.1 km/h Low: 0 - 2.2 km/h
Travel speeds (grouser shoes)	High: 0 - 4.1 km/h Low: 0 - 2.2 km/h
Gradeability	30° (58%) continuous

Weights and ground pressure

Equipped with 1.10 m arm and 0.066 m³ (PCSA heaped) bucket.

	Operating weight	Ground pressure
4-Pillar canopy version		
250 mm rubber shoes	2 450 kg	32 kPa (0.33 kgf/cm ²)
250 mm grouser shoes	2 510 kg	32 kPa (0.33 kgf/cm ²)
Cabin version		
250 mm rubber shoes	2 520 kg	33 kPa (0.34 kgf/cm ²)
250 mm grouser shoes	2 580 kg	34 kPa (0.35 kgf/cm ²)

Front-end attachments

BACKHOE BUCKETS

ISO 7451 capacity	Width		No. of teeth	Weight	Use	
	Without side cutters	With side cutters			1.10 m Short arm	1.41 m Long arm
0.04 m ³	260 mm	300 mm	2	41 kg	A	A
0.045 m ³	310 mm	350 mm	3	44 kg	A	A
0.066 m ³	420 mm	460 mm	3	49 kg	A	B
0.085 m ³	510 mm	550 mm	4	56 kg	B	C
Arm crowd force					12.4 kN (1 270 kgf)	10.6 kN (1 080 kgf)
Bucket digging force					22 kN (2 240 kgf)	

A: General digging B: Light-duty digging C: Loading

Boom swing angle Left 80°, Right 50°

Dimensions

Unit: mm

The 4-pillar canopy or cabin can be mounted on the upper structure according to job needs and applicable regulations.

The 4-pillar canopy and cabin conform to TOPS (ISO 12117) and FOPS (ISO 10262, Level I) requirements.

- Notes:
1. The illustration shows the cabin version equipped with 250 mm rubber shoes.
 2. Values are identical for cabin and canopy versions.

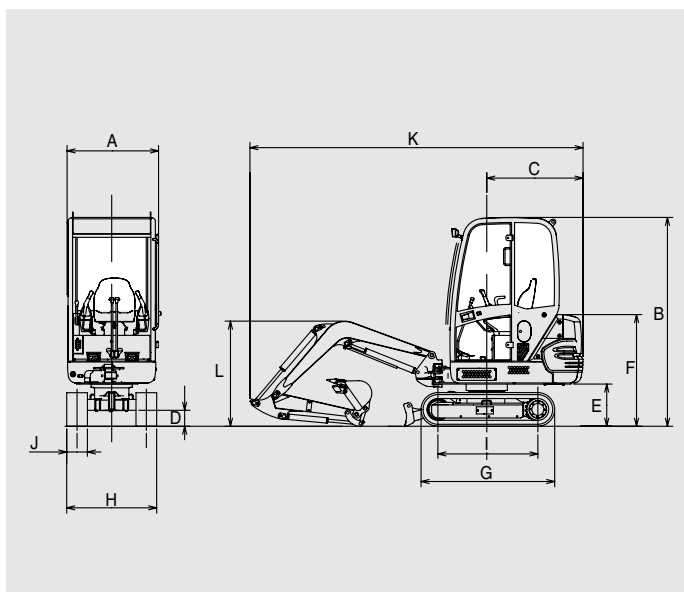

	Unit: mm
	ZX25
A Overall width	1 350
B Canopy / Cabin height	2 390
C Rear-end swing radius	1 240
D Minimum ground clearance	325
E Counterweight clearance	540
F Engine cover height	1 310
G Undercarriage length	1 790
H Undercarriage width	1 400
I Sprocket centre to idler centre	1 350
J Track shoe width	250
K Maximum transport length	4 250
L Overall height of boom	1 300

Working ranges

Unit: mm

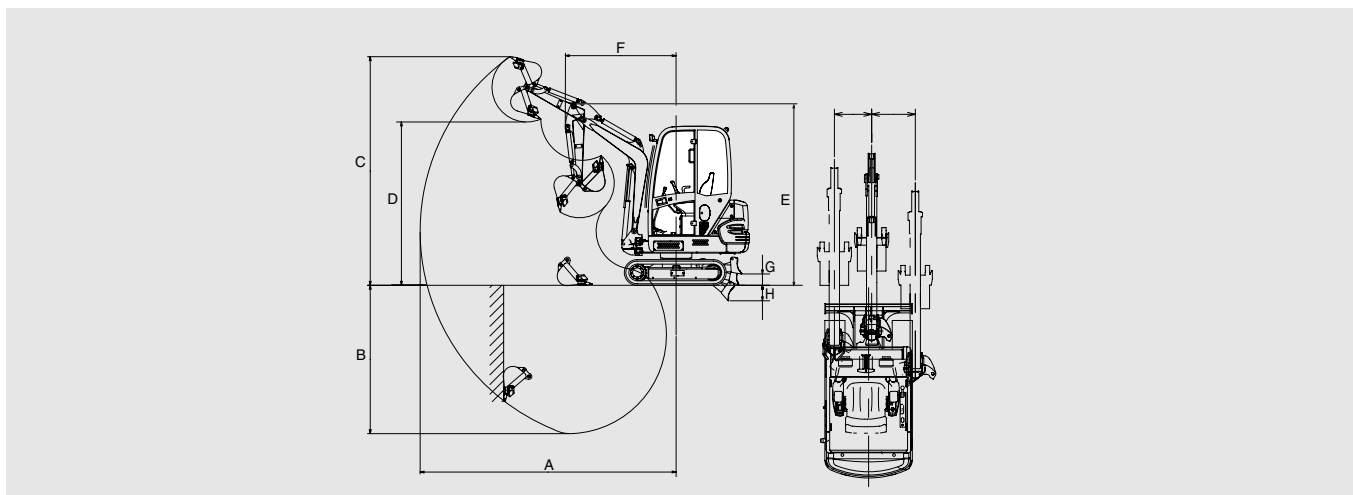

- Notes:
1. The illustration shows the cabin version equipped with 0.066 m³ bucket, 1.1 m arm and 250 mm rubber shoes.
 2. Values are identical for cabin and canopy versions.

Unit: mm

	ZX25	
	Canopy & Cabin	
	1.10 m arm	1.41 m arm
A Maximum digging reach	4 370	4 650
B Maximum digging depth	2 440	2 740
C Maximum cutting height	4 140	4 300
D Maximum dumping height	2 950	3 120
E Transport height	3 260	3 270
F Minimum swing radius	1 700	1 750
G Blade bottom highest position (above ground level)	390	390
H Blade bottom lowest position (below ground level)	355	355
Maximum boom-swing angle	L80° / R50°	L80° / R50°
Offset distance	L620 / R480	L620 / R480

LIFTING CAPACITIES ZX25

Metric measure

(Equipped with cabin)

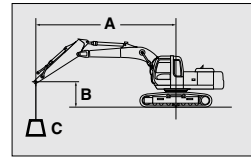

A: Load radius
B: Load point height
C: Lifting capacity

ZX25 WITH BLADE ABOVE GROUND



Rating over-side or 360 degrees



Rating over-front

Unit: kN

	Load point height	Load radius						At max. reach		
		2 m		3 m		4 m		meter		
Arm 1.10 m	2 m			4.57	3.94			2.69	2.28	4.09
Bucket 0.066 m ³	1 m			4.31	3.69	2.70	2.29	2.50	2.12	4.20
Rubber shoes 250 mm	0 m	7.64	6.42	4.09	3.47			2.69	2.28	3.97
	-1 m	7.71	6.48	4.06	3.44			3.61	3.07	3.29

ZX25 WITH BLADE ON GROUND

Unit: kN

Conditions	Load point height	Load radius						At max. reach		
		2 m		3 m		4 m		meter		
Arm 1.10 m	2 m			*5.01	3.94			*4.61	2.28	4.09
Bucket 0.066 m ³	1 m			*6.62	3.69	*5.02	2.29	*4.81	2.12	4.20
Rubber shoes 250 mm	0 m	*9.36	6.42	*7.67	3.47			*4.97	2.28	3.97
	-1 m	*11.22	6.48	*6.88	3.44			*4.82	3.07	3.29

ZX25 WITH BLADE ABOVE GROUND

Unit: kN

Conditions	Load point height	Load radius						At max. reach		
		2 m		3 m		4 m		meter		
Arm 1.41 m	2 m			*4.20	3.99	3.39	2.36	2.93	2.02	4.38
Bucket 0.045 m ³	1 m			5.22	3.72	3.30	2.28	2.76	1.87	4.47
Rubber shoes 250 mm	0 m	9.14	6.38	4.95	3.45	3.21	2.19	2.92	1.98	4.26
	-1 m	9.11	6.35	4.86	3.36			3.67	2.53	3.67

ZX25 WITH BLADE ON GROUND

Unit: kN

Conditions	Load point height	Load radius						At max. reach		
		2 m		3 m		4 m		meter		
Arm 1.41 m	2 m			*4.20	3.99	*4.27	2.36	*4.11	2.02	4.38
Bucket 0.045 m ³	1 m			*5.95	3.72	*4.67	2.28	*4.31	1.87	4.47
Rubber shoes 250 mm	0 m	*10.53	6.38	*7.43	3.45	*5.05	2.19	*4.54	1.98	4.26
	-1 m	*12.53	6.35	*7.29	3.36			*4.62	2.53	3.67

- Notes:
1. Ratings are based on ISO 10567.
 2. Lifting capacity does not exceed 75% of tipping load with the machine on firm, level ground or 87% full hydraulic capacity.
 3. The load point is a hook (not standard equipment) located on the back of the bucket.
 4. An asterisk mark (*) indicates load limited by hydraulic capacity.
 5. 0 m = Ground.

Standard Equipment

Standard equipment may vary by country, so please consult your Hitachi dealer for details.

ENGINE

- Water-separator for engine fuel system

HYDRAULIC SYSTEM

- Hydraulic pilot type control levers for boom, arm, bucket, swing and travel
- Mechanical linkage type control levers for boom swing, blade and hydraulic PTO
- Pilot control shut-off levers for boom, arm, bucket, swing and travel
- Two-speed travel system

- Swing parking brake

- Hydraulic piping for breaker

CANOPY (CABIN)

- One work lamp
- Heater*
- Windshield wiper*
- Windshield washer*
- Windshield defroster*
- Evacuation hammer*
- Seat belt
- Wrist rest
- 12 V outlet

Note:* For Cabin version

UNDERCARRIAGE

- 250 mm rubber shoes
- Semi-long stay blade

FRONT ATTACHMENTS

- 2.10 m boom
- 1.10 m arm
- 0.066 m³ hoe bucket
- O-ring type pin-seals for hoe bucket
- HN bushing

Optional Equipment

Optional equipment may vary by country, so please consult your Hitachi dealer for details.

CANOPY (CABIN)

- One work lamp

UNDERCARRIAGE

- 250 mm grouser shoes

FRONT ATTACHMENTS

- 1.41 m arm

These specifications are subject to change without notice.

Illustrations and photos show the standard models, and may or may not include optional equipment, accessories, and all standard equipment with some differences in colour and features.

Before use, read and understand the Operator's Manual for proper operation.

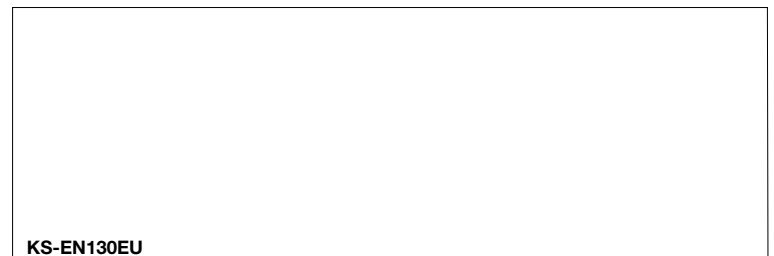

KS-EN130EU