

VACUUM LIFTERS



The JVL line is a separate product range. Suction cups are in fact equipped with independent controls, built-in battery and safety devices. They are used for fast and safe handling of glass panes and flat panels, even in combination with other machines fitted with a hook lifting system.

- ✓ JVL450 (4 in-line + 2 extra suction cups)
- ✓ JVL600 (4 in-line + 2 extra suction cups)



Technical Information

Dimension LxWxH	1305 x 250 x 285 mm	
N. of Pads	4 + 2	
Weight	56 kg + 12	
Elect. System	12V - 7 Ah	
Pad Diameter	300 mm	
Max SWL	450 kg	
Tilting Angle	0°/90°	
Swiveling Angle	360°	
N. of Pads	4	6
Factory Use	300 kg	450 kg
Building site use	300 kg	450 kg

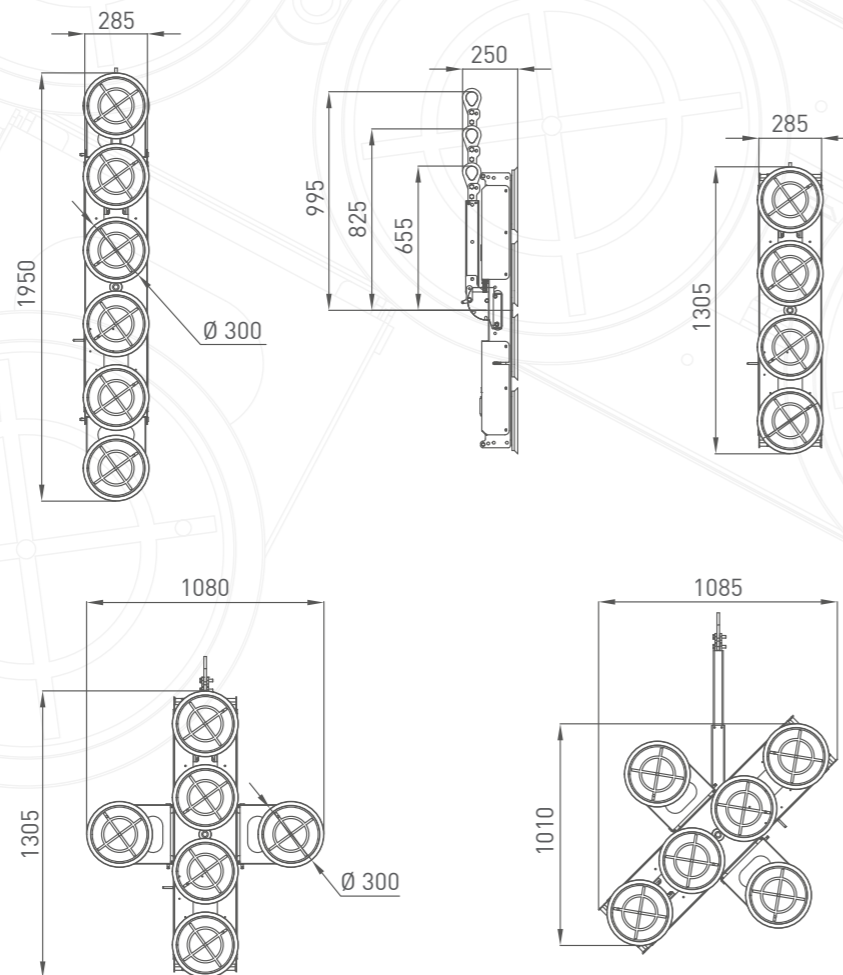

Technical Information

Dimension LxWxH	1680 x 250 x 285 mm	
N. of Pads	4 + 2	
Weight	70 kg + 15	
Elect. System	12V - 7 Ah	
Pad Diameter	400 mm	
Max SWL	600 kg	
Tilting Angle	0°/90°	
Swiveling Angle	360°	
N. of Pads	4	6
Factory Use	400 kg	600 kg
Building site use	400 kg	600 kg

