

D85E-21

CRAWLER DOZER

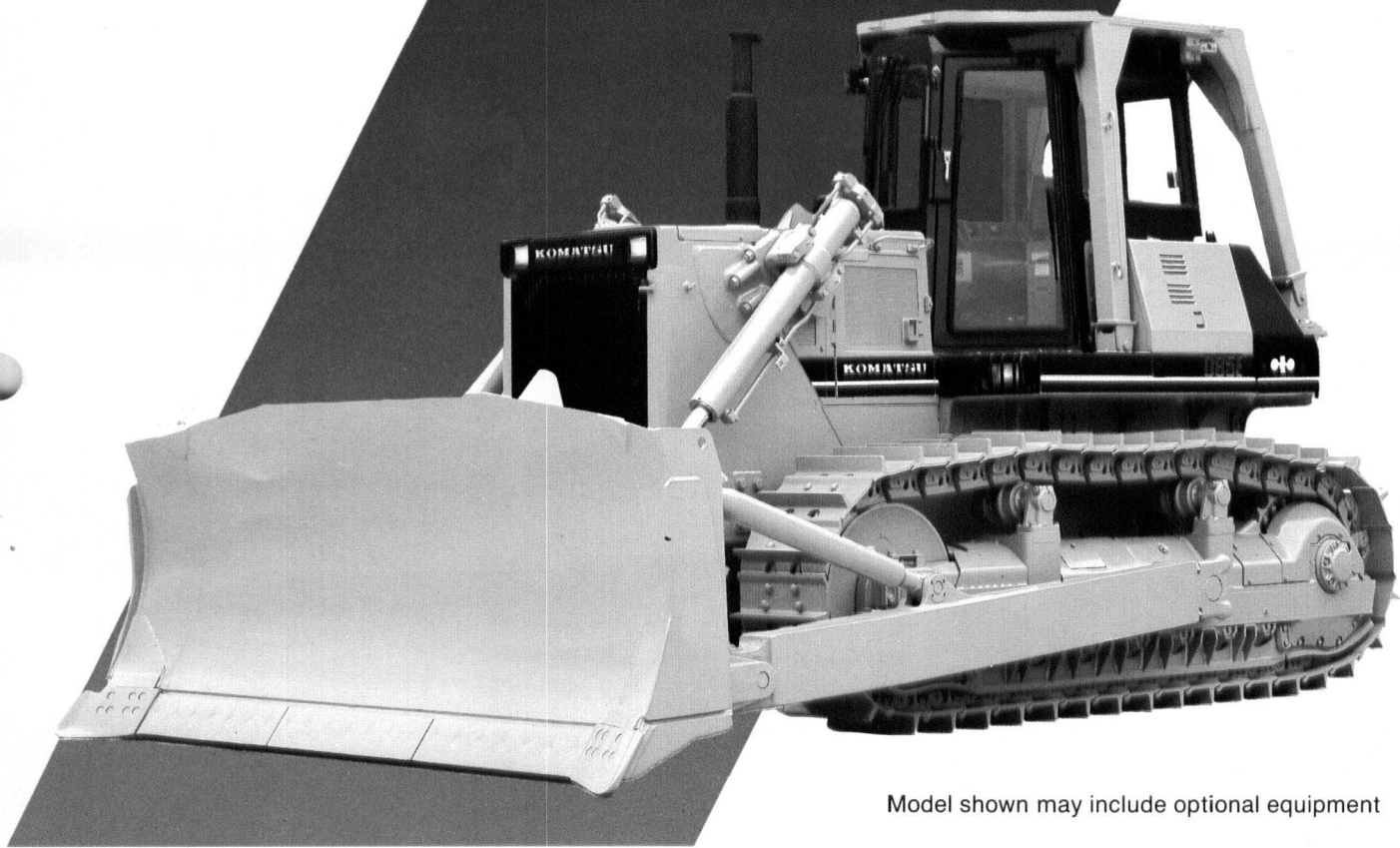

Model shown may include optional equipment

KOMATSU: The Quality is Standard.

FLYWHEEL HORSEPOWER: 168 kW (225 HP) @ 2000 RPM. OPERATING WT: 28410 kg (62,400 lb)

BLADE CAPACITY: 5.2 m³-8.5 m³ (6.8 yd³-11.1 yd³)

Outstanding productivity and efficiency

- Low center of gravity provides excellent stability and powerful traction.
- The Komatsu S6D125 engine delivers maximum fuel efficiency.
- Large capacity blade boosts productivity and efficiency.

Minimum downtime

- Advanced monitoring system helps prevent minor problems from becoming major ones.
- Tilt back ROPS cab for easy component access.
- Komatsu-built components extend service life and endurance.

Operator comfort

- Large glass area provides excellent view of blade edge, ripper shank and work area.
- Efficient arrangement of levers, pedals and instruments reduces operator fatigue.

Komatsu D85E-21 Bulldozer Designed for Maximum Production and Economy

Outstanding Productivity

Low center of gravity and high stability mean extra-powerful traction

Track on ground of 3050 mm (10') and 2000 mm (6'7") track gauge develop excellent stability and assure maximum power transfer to the ground for powerful traction. The low profile design assures excellent machine balance making the D85E-21 dynamically stable and controllable for outstanding productivity.

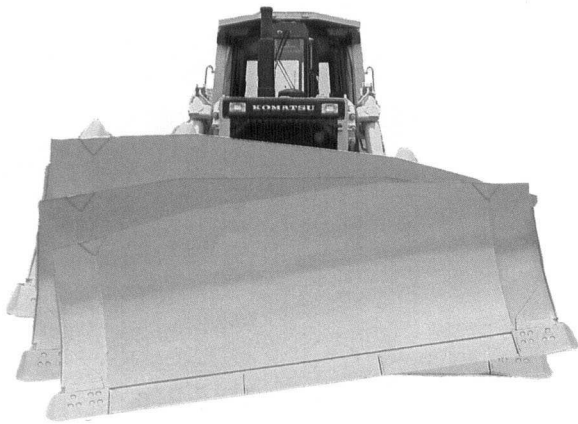
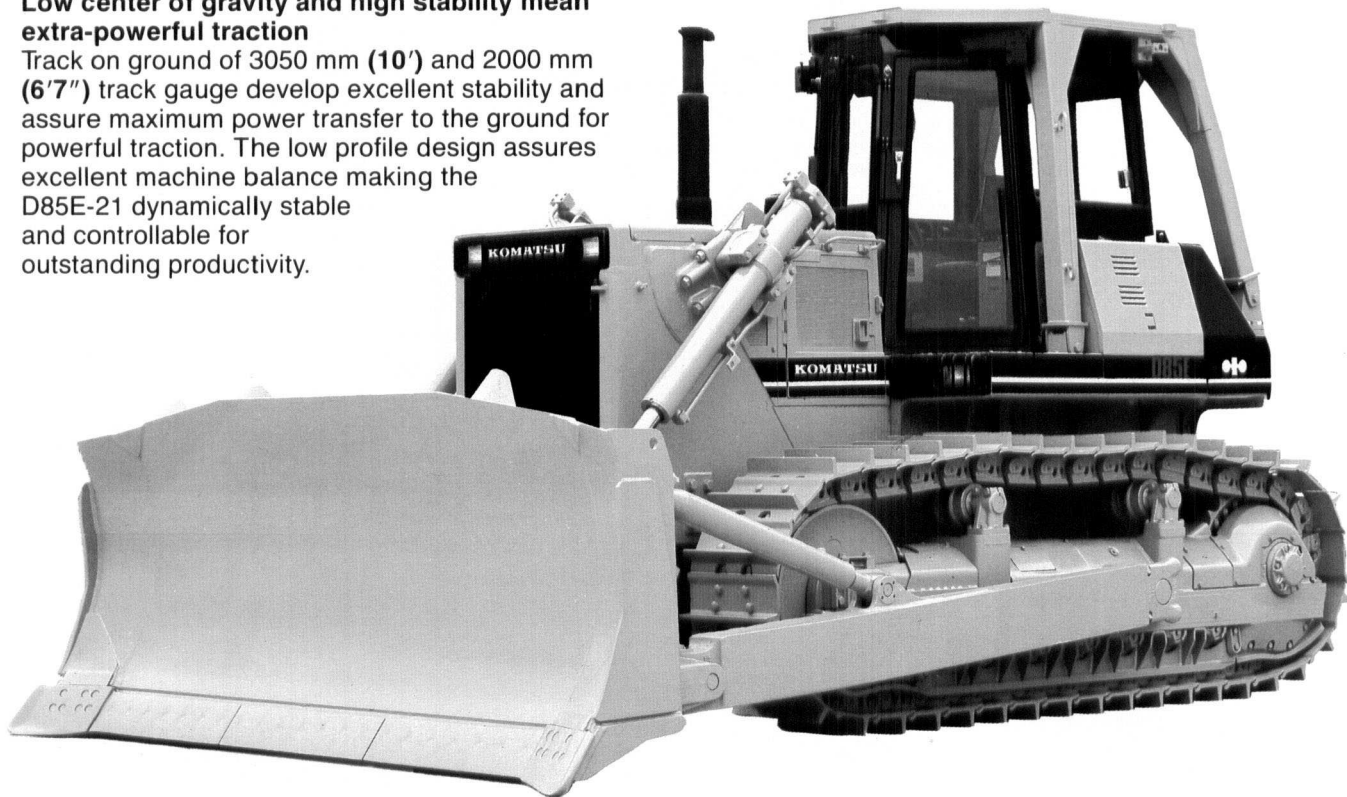

Superior blade and ripper performance

A large blade capacity of 8.5m³ (11.1 yd³) means increased production. High tensile strength steel at the front and side of the blade increases durability. All blade tilt hoses and piping are mounted inside the dozer push arm for added protection and reduced downtime.

Ripping is made easy with excellent digging performance and great penetration forces.

High Powered Fuel Efficient Engine

High output Komatsu engine means added productivity

The Komatsu S6D125 engine turns out 225 HP (212 kW) and a full 102 kg-m (738 ft-lb) of torque for high powered dozing and ripping. The Komatsu reputation for designing quality engines assures you long life and reliable operation.

The Komatsu S6D125 engine provides maximum fuel economy

Its advanced fuel-efficient design makes the S6D125 one of today's most economical, energy-saving engines. Features such as 4 valves per cylinder, swirl intake ports, roller type cam followers and direct injection all work together keeping fuel consumption at a minimum.

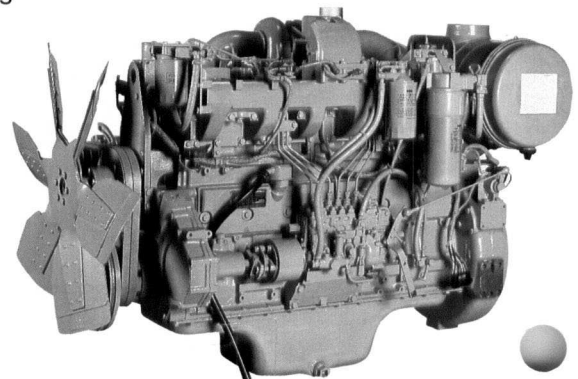



DIMENSIONS

(Equipped with low profile ROPS and cab, and U-dozer. See table below for dimensions with optional blades.)

Unit: mm (ft.in)

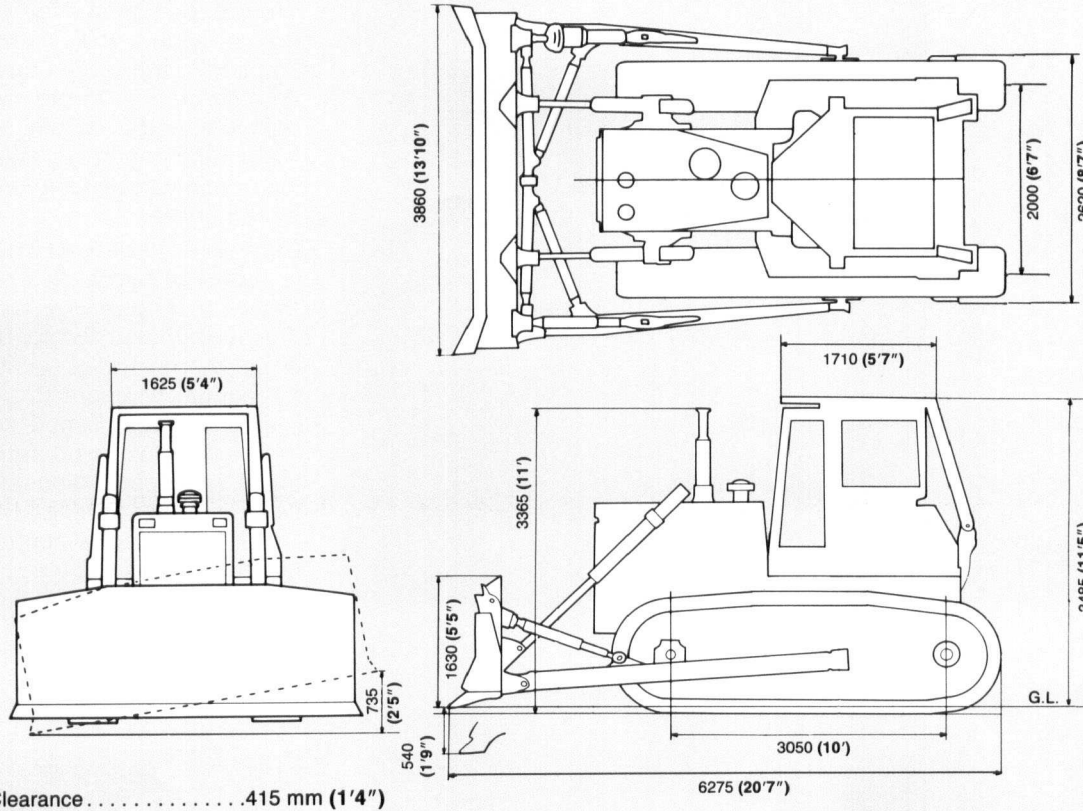

HYDRAULIC SYSTEM

Hydraulic control unit: Gear-type pump with a capacity (discharge flow) of 194 ltr. (51 U.S. gal)/min. at rated engine RPM. Relief valve setting 195 kg/cm² (2,773 psi)

Control valves:

- Two control valves for straight-tilt dozer and U-dozer
Positions: Blade lift Raise, hold, lower and float
Blade tilt Left, hold and right
- Additional control valve required for ripper
Positions: Ripper lift Raise, hold, and lower

Hydraulic cylinders: Double-acting, piston type

	Number of cylinders	Bore
Blade lift	2	110 mm (4.33")
Blade tilt	1	160 mm (6.30")
Ripper lift	2	140 mm (5.51")

Hydraulic capacity:

Straight-tilt dozer,
Semi U-dozer and U-dozer 101 ltr. (27 U.S. gal)
Angledozer 95 ltr. (25 U.S. gal)
Ripper equipment
(Additional volume) 21 ltr. (5.5 U.S. gal)



DOZER EQUIPMENT

Use of high tensile-strength steel in moldboard for strengthened blade construction. Hydraulic pipings for blade tilting are housed inside the dozer frame and protected from damage.

	Overall length with dozer	*Blade capacity	Blade length x height	Max. lift above ground	Max. drop below ground	Max. tilt adjustment	Additional Weight		Additional ground pressure
							Dozer equipment	Hydraulic control unit	
Straight-tilt dozer	5710 mm (18'9")	5.2 m ³ (6.8 yd ³)	3725 mm x 1390 mm (12'3" x 4'6")	1360 mm (4'6")	540 mm (1'9")	735 mm (2'5")	3723 kg (8,210 lb)	770 kg (1,700 lb)	0.13 kg/m ² (1.85 psi/12.7 kPa)
Angledozer	6020 mm (19'9")	3.9 m ³ (5.1 yd ³)	4365 mm x 1130 mm (14'4" x 3'8")	1425 mm (4'8")	580 mm (1'11")	500 mm (1'8")	3840 kg (8,470 lb)	770 kg (1,700 lb)	0.13 kg/m ² (1.85 psi/12.7 kPa)
Mechanical-angle power-tilt dozer	6040 mm (19'10")	3.6 m ³ (4.7 yd ³)	4515 mm x 1055 mm (14'10" x 3'6")	1385 mm (4'7")	615 mm (2')	520 mm (1'8")	4220 kg (9,300 lb)	770 kg (1,700 lb)	0.15 kg/m ² (2.13 psi/14.7 kPa)
U-dozer	6275 mm (20'7")	8.5 m ³ (11.1 yd ³)	3860 mm x 1630 mm (12'8" x 5'5")	1360 mm (4'7")	540 mm (1'9")	755 mm (2'6")	4330 kg (9,320 lb)	770 kg (1,700 lb)	0.14 kg/m ² (1.99 psi/13.7 kPa)

*Blade capacities are based on SAE recommended practice J1265.



Operator Comfort

Large cab windows provide panoramic view

The cab design and large glass area provide a wide visual range. In addition to the rubber cushioned floor frame mount, the cab has built-in sound-absorbing urethane foam and is entirely sealed, resulting in minimal noise and vibration disturbances.

Convenient controls and responsive hydraulics reduce operator fatigue

The seat rotates 15° for optimum visual range, and to reduce operator fatigue. The sensitive hydraulic system provides simple fine control for precise dozing operations. A demand valve proportions blade oil flow between the lift and tilt circuits for efficient precise control with no time lag.

Minimum Downtime

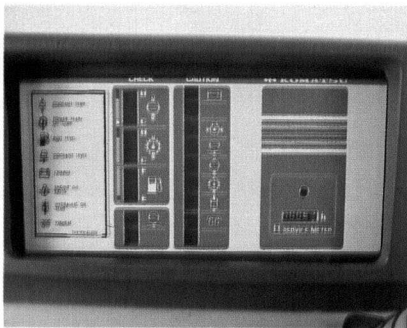

Advanced electronic display panel prevents minor problems from becoming major ones

Minor problems don't develop into serious breakdowns because all check-before-starting items and operating warnings are clearly displayed on the liquid crystal monitoring panel. As a result, the operator can concentrate on the controls while the monitoring system constantly checks and informs him of the machine's condition.

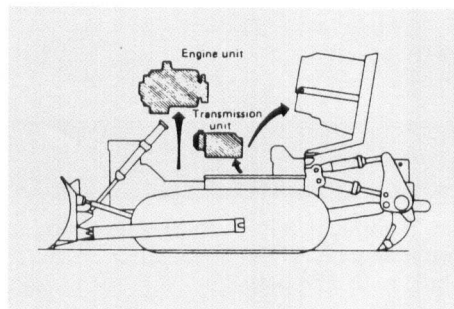

ROPS and operator's compartment can tilt back for easy access

Since the operator's compartment and ROPS can be tilted back, mounting and dismounting power-train components is fast and efficient.

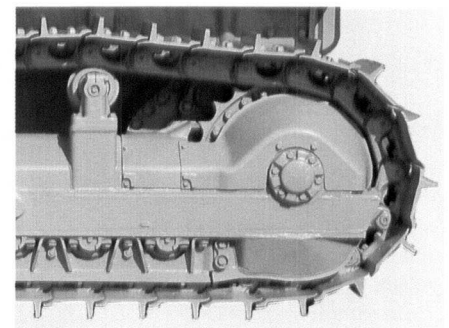
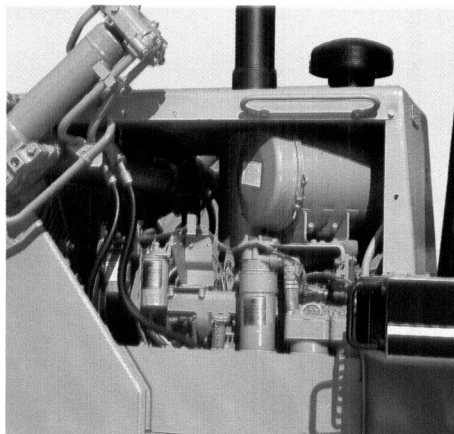

Bolt-on sprocket segments reduce downtime

Since the bolt-on segments can be easily replaced in the field downtime is minimized.

Grouped maintenance stations reduce service times

Access doors provide easy entry to all maintenance points. Filters and grease points are grouped together for fast easy servicing.

SPECIFICATIONS



ENGINE

Komatsu S6D125, 4-cycle, water-cooled, turbocharged diesel engine. 6 cylinders of 125 mm (4.92") bore x 150 mm (5.91") stroke provide 11.04 ltr. (674 in³) piston displacement. Flywheel horsepower:

225 HP (168 kW) at 2000 RPM (SAE J1349)

Max. torque: 102 kg-m (738 ft-lb) at 1400 RPM.

Direct-injection fuel system with mechanical all-speed governor. Gear-pump-driven force-lubrication with full-flow filter. Dry-type air cleaner with automatic dust evacuator for longer element service and dust indicator for simplified maintenance. 24 V/7.5 kW electrical starting motor. 24 V/50 A alternator. 2 x 12 V/170 Ah batteries. No fuel injection adjustment required up to altitudes of 3000 m (9,840 ft) to keep up with rated engine output. Corrosion resistor prevents dust and scale from being generated in the coolant.



TORQFLOW TRANSMISSION

Komatsu's unique TORQFLOW transmission consists of a water-cooled, 3-element, 1-stage, 1-phase torque converter and a planetary-gear, multiple-disc clutch transmission both of which are hydraulically actuated and force-lubricated for optimum heat dissipation. It allows single-lever control of all speed (3 forward and 3 reverse) and directional changes. Gearshift lock lever and neutral start switch prevent the machine from accidental starts.

Travel speeds km/h (MPH)

	Forward	Reverse
1st	0— 3.8 km/h (2.4 MPH)	0— 4.9 km/h (3.0 MPH)
2nd	0— 6.8 km/h (4.2 MPH)	0— 8.5 km/h (5.3 MPH)
3rd	0—11.8 km/h (7.3 MPH)	0—14.3 km/h (8.9 MPH)

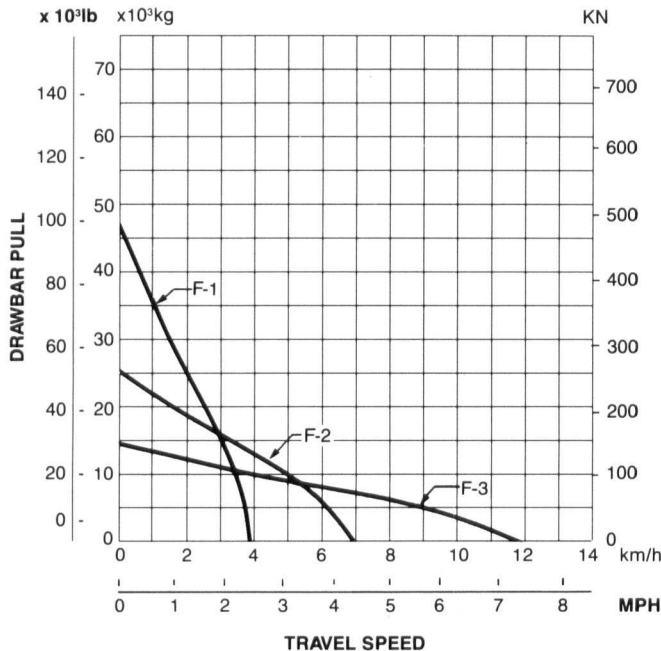

Note: The DRAWBAR PULL and TRAVEL SPEED may be subject to change depending on the ground conditions and machine weight.



STEERING

Lever-controlled, wet, multiple-disc steering clutches are hydraulically boosted and hand operated. Wet, contracting band, foot operated steering brakes allow easy light touch steering/braking actions. Steering clutches and brakes are interconnected.



FINAL DRIVE

Equipped with spur gear, double-reduction final drives. Segmented sprockets are installed on the hub with bolts for easy in-field replacement.



UNDERCARRIAGE

Suspension Oscillation-type equalizer bar
Track roller frame Box-section, high-tensile-strength steel construction.

Rollers and idlers Lubricated idlers, track and carrier rollers are sealed with floating seals.

Number of track rollers 7 each

Number of carrier rollers 2 each

Sealed and lubricated track Assembled single grouser shoes. Unique dust seals prevent entry of dust into pin-to-bushing clearances for extended service. Track tension is easily adjusted with grease gun.

Number of shoes (each side) 41

Grouser height 72 mm (2.8")

Shoe width (standard) 560 mm (22")

Ground contact area 34160 cm² (5,295 in²)



SERVICE REFILL CAPACITIES

Coolant 79 ltr. (20.9 U.S. gal)

Fuel tank 480 ltr. (126.8 U.S. gal)

Engine 24 ltr. (6.3 U.S. gal)

Torque converter, transmission, bevel gear case, steering case 90 ltr. (23.8 U.S. gal)

Final drive (each side) 41 ltr. (10.8 U.S. gal)

Undercarriage (each side) 3 ltr. (0.8 U.S. gal)



OPERATING WEIGHT (approximate)

Operating weight, including U-dozer, operator, standard equipment, rated capacity of lubricant coolant, full fuel tank, ROPS and cab and multishank ripper 28410 kg (62,400 lb)

STANDARD EQUIPMENT

- Hydraulic track adjusters
- 24 V/50 A alternator
- Back-up alarm
- 2 x 12 V/170 Ah batteries
- Cooling fan, blower type
- Decelerator pedal
- Dry-type air cleaner with precleaner
- Final drive case wear guard
- Radiator mask hinged and perforated (single)
- 7 roller track frames
- Hinged 1-piece radiator guard
- Lighting system (including 1 rear and 4 front lights)

- Power train guards (3 piece)
- Radiator, in line core
- ROPS brackets
- Instrument panel, electronic display/monitoring system: check light for coolant level, gauges for coolant temperature, power train oil temperature and fuel level, pilot indicator for pre-heating, service meter, electric warning alarm and lights for engine oil pressure, coolant level, coolant temperature and power train oil temperature, and a warning light for electric charge.

- Segmented sprockets
- 560 mm (22") extreme service shoe, sealed and lubricated
- 24 V/7.5 kW electric starter
- Suspension seat with seat belt
- TORQFLOW transmission
- Track-roller guards
- Wet-type steering clutches and brakes
- Wear resistant fan pulley
- Muffler with rain cap
- Precleaner and exhaust pipe hole clearance cover
- Front pull hook

ATTACHMENTS AND OPTIONAL EQUIPMENT

ROPS CANOPY: Meets ISO 3471 and SAE J1040a ROPS standards, as well as ISO 3449 FOPS standards.

Weight 1040 kg (2,290 lb)

Roof Dimensions

Length 1665 mm (5'6")

Width 1625 mm (5'4")

Height from compartment floor

. 1775 mm (5'10")

Ground pressure

. 0.03 kg/cm² (0.43 psi)

STEEL CAB: Includes floor mat, inside rear view mirror, and wipers (front, rear, left and right door).

Weight 500 kg (1,100 lb)

Dimensions

Length 1685 mm (5'6")

Width 1575 mm (5'2")

Height from compartment floor

. 1670 mm (5'6")

Ground pressure

. 0.01 kg/cm² (0.14 psi)

RIGID TYPE DRAWBAR:

Additional weight 233 kg (513 lb)

GUARDS AND COVERS:

Hinged, 2-piece radiator guard, pre-cleaner guard, cylinder guard, engine side cover perforated, engine side cover enclosed, cylinder stay cover, strengthened rear cover, vandalism protection locks.

OTHERS:

Towing winch. Wire rope. Fairlead. Coolant preheater. Reversible fan. Cab heater and defroster. Engine hood perforated. Air-conditioner. Tool kit. Radiator core protective grid. Swing type drawbar. Radiator shutter. Rear power control unit. ROPS sweeps. Short exhaust pipe. Cab sun visor. Fire extinguisher. Heavy-duty underguards. Large capacity (220 Ah) battery. Large capacity (11 kW) starting motor. Tilt-back operator's compartment.

TRACK SHOE SELECTION

	Additional weight kg (lb)	Ground contact area cm ² (in ²)	Additional ground pressure kg/cm ² (psi)
610 mm (24") extreme service shoe	+ 150 (330)	37210 (5,767)	- 0.07 (0.15)
660 mm (26") extreme service shoe	+ 310 (680)	40260 (6,240)	- 0.12 (0.26)
560 mm (22") single grouser shoe	- 468 (1,032)	34160 (5,295)	- 0.01 (0.02)
610 mm (24") single grouser shoe	- 432 (952)	37210 (5,767)	- 0.17 (0.08)
660 mm (20") single grouser shoe	- 396 (873)	40260 (6,240)	- 0.13 (0.29)

Multishank ripper: Rigid, hydraulically controlled parallelogram type ripper with 3 shanks. Digging angle fixed at 54.°

Additional weight (including hydraulic control unit) 2700 kg (5,950 lb)

Beam length 2227 mm (7'4")

Maximum lift above ground 555 mm (1'10")

Maximum digging depth 665 mm (2'2")

Additional ground pressure 0.08 kg/cm² (1.14 PSI)