

KOMATSU®

HD325-6

HORSEPOWER
GROSS 379 kW 508 HP
NET 364 kW 488 HP
MAX. GROSS VEHICLE WEIGHT
65200 kg 143,740 lb

HD
325



Photo may include optional equipment.



OFF-HIGHWAY TRUCK

PRODUCTIVITY FEATURES

Clean, fuel-efficient engine

Common-rail fuel injection system provides high injection pressure for low emission. Ductile cast-iron pistons and helical intake ports make this engine a great fuel saver.

Mode-switching system

Electronic engine control provides superior climbing ability and outstanding fuel economy.

High power mode with superior operating power suited to job sites where much time is spent working on inclines.

Economy mode with reduced fuel consumption and operating noise should be used when working on level sites or under conditions where machine load is lighter.

Automatic idling setting system (AISS)

This system facilitates quick engine warm-up and cab cooling/warming with air conditioner.

When setting the system ON, engine idle speed is kept at 1000 rpm when coolant temperature is 50°C(122°F) or lower. Speed automatically returns to 650 rpm when coolant temperature reaches 50°C(122°F).

7-speed, fully automatic K-ATOMiCS transmission

The K-ATOMiCS (Komatsu Advanced Transmission with Optimum Modulation Control System) automatically selects the optimum gear according to vehicle speed, engine speed and the shift position you've chosen. The result: the best gear for any driving situation.



K-ATOMiCS
(Komatsu Advanced Transmission with Optimum Modulation Control System)

Oil-Cooled multiple-disc retarder and optional exhaust retarder

The truck can be decelerated without frequent use of the brakes, allowing you to travel safer at higher speeds, even down long, steep slopes.

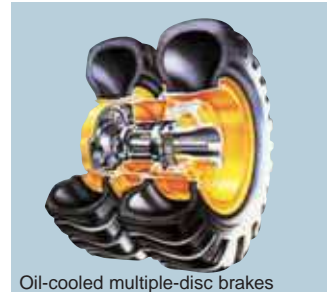

Oil-cooled multiple-disc brakes

Long wheelbase and wide tread

With an extra-long wheelbase, a wide tread and an exceptionally low center of gravity, the HD325-6 hauls the load at higher speed for more production, and delivers supreme driving comfort over rough terrain.

Big body

A wide target area makes for easy loading with minimal soil spillage and more efficient hauling.

Small turning radius

The MacPherson strut type front suspension has a special A-frame between each wheel and the main frame. The wider space created between the front wheels and the main frame increases the turning angle of the wheels. The larger this turning angle, the smaller the turning radius of the truck.

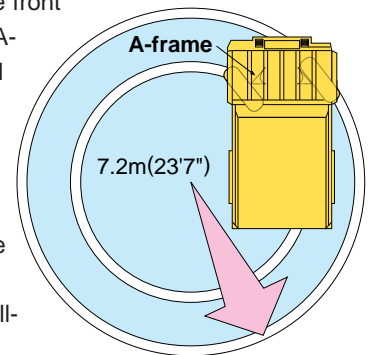

OPERATOR ENVIRONMENT

K-ATOMiCS with “Skip-shift” Function

An electronically controlled valve is provided for each clutch pack in the transmission for independent clutch engagement/disengagement. It enables an ideal change in clutch modulation pressure and torque cut-off timing in response to travel conditions. This system and newly added “skip-shift” function ensure smooth shifting and responsive acceleration.

“Skip-shift” function

Optimum travel speed automatically selected in response to angle of ascent.

Reduced frequency of shift downs and smoother operation are provided.

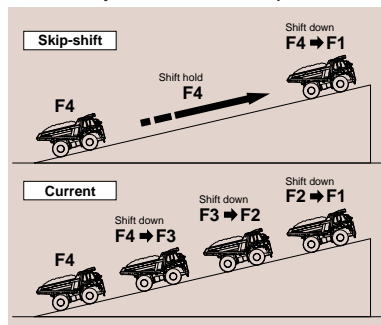

Hydropneumatic suspension

All four wheels have hydropneumatic suspension with a fixed throttle damper control valve that greatly reduces pitching, rolling and bouncing over rough terrain.

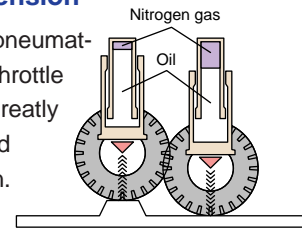

Ideal driving position settings

The 5-way adjustable operator seat and the tilt-telescopic steering column create an optimum driving posture, for increased driving comfort and more control over the machine's operations.

See everything in quiet comfort

Wide windows in the front, side and back, plus plenty of space in the richly upholstered interior, give you a quiet, comfortable environment from which to see and control every aspect of your work.

EXCELLENT RELIABILITY AND DURABILITY

Sturdy, refined frame

Cast-steel components are employed in the main frame in critical areas where loads and shocks are most concentrated.

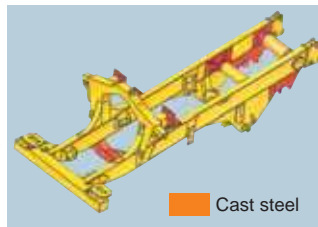

Rigorous dump body design

The standard dump body is made of **130 kg/mm²** 184,900 ps high-tensile-strength steel for excellent rigidity and reduced maintenance cost. The V-shape design also increases structural strength. The side and bottom plates of the dump section are reinforced with ribs for added strength.

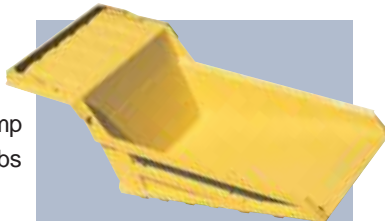

Reliable hydraulic system

The oil cooler is installed below the retarder, improving the reliability of the hydraulic system during sudden temperature rises. Further, in addition to the main filter, a 52-micron line filter is set at the entrance to the transmission control valve. This system helps prevent secondary faults.

Excellent footwork and durable power train

By adopting electronic modulation on all levels, peak torque when shifting is reduced, raising the endurance of the power train.

Electronic devices for excellent operation

In the harness connection, a dual-lock connector is used to prevent loosening from vibrations and contact failure. Also, the base boards for controllers and other devices are fixed by molding (with resin), realizing high water, dust and vibration resistance.

Protection functions supported by electronic control

Item	Function
Downshift inhibitor	Even if the driver downshifts accidentally, a speed appropriate to the current gear is automatically set, preventing over-runs.
Over-run inhibitor	When descending grades, if the vehicle's speed surpasses the maximum for the current gear, the rear brakes automatically operate, preventing over-runs.
Reverse inhibitor	The vehicle is prevented from moving backward when operating the body.
Forward/Reverse shift inhibitor	This device makes it impossible to shift from forward to reverse when the vehicle's speed surpasses 4 km/hour.
Anti-hunting system	When running near a shift point, smooth automatic shifting takes place.
Neutral safety	The engine is prevented from starting when the shift lever is not in neutral.

EASY MAINTENANCE

Adjustment-free brakes

The front service brakes and the parking brake are adjustment-free caliper disc type.

Centralized greasing points and oil filters

Greasing points have been centralized at three locations. Fuel and engine oil filters are also located together on the left-hand remote mount, for easy, remote inspection from the ground.

Advanced monitoring system

Availability rate with vehicle monitoring system

The electronic display panel shows current vehicle condition and how to fix them with action codes and check results with service codes. Thus, vehicle management is easier and the working rate is higher. At the same time the monitoring data is saved to be used for later troubleshooting.

Action code display function

If an abnormality on the truck occurs, an "E" appears on the electronic display panel with the appropriate action code, which notifies the operator how to deal with the abnormality. The operator never misses an abnormality and can take the proper corrective action.



Messages interchange once every second.

Service code display and memory function

The contents of each controller are displayed on the electronic display panel in service codes. The stored vehicle information can be downloaded to a personal computer. This enables a quick response to problems and shortens maintenance time. This also shows the truck's current condition and facilitates management.



Network functions

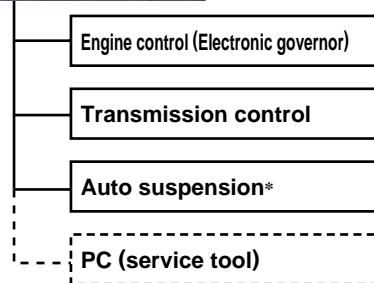

(*OPTION)



VALUE-ENHANCING OPTIONS

Auto Retard Speed Control (ARSC)

ARSC is available as an option. This allows you to simply set the downhill travel speed and go down slopes at a constant speed (travel speed permitted from brake performance). As a result, you can concentrate on steering. The speed can be set at increments of **1km/h** 0.6mph per one click ($\pm 5\text{km/h}$ 3.1mph of setting speed) to match the optimum speed for the slope. Also, when it is predicted that the retarder oil temperature becomes overheat, since the retarder oil temperature is always monitored, operator is informed this by warning lamp.

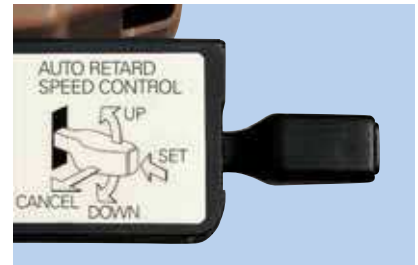

Body

	Linerless body (standard)	Rock body
Body type		
Applications	Hauling clay, sand and gravel	Hauling rocks
Features	<ul style="list-style-type: none"> •Suitable for loading clay, sand and gravel •Liner is not incorporated 	<ul style="list-style-type: none"> •Suitable for loading rocks at quarries, limestone mining site or construction work •Steel liner is incorporated throughout the entire body
Body capacity:Struck Heaped (2:1)	18 m³ 23.5 yd ³ 24 m³ 31.4 yd ³	18 m³ 23.5 yd ³ 24 m³ 31.4 yd ³
Body inside dimensions:		
Length	5500 mm 18'1"	5485 mm 18'0"
Width	3380 mm 11'1"	3355 mm 11'0"
Max.depth	1440 mm 4'9"	1430 mm 4'8"
Loading	3200 mm 10'6"	3200 mm 10'6"

Side extension (optional) is available for each body.

PLMII (IC card type payload meter)

This system allows the production volume and the working conditions on the dump truck to be analyzed and managed directly via a personal computer. It can store up to 2900 working cycles.

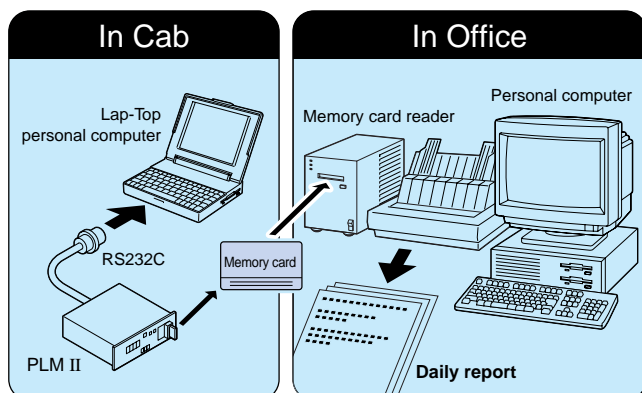

* The memory card, card reader and software for data processing are optionally available.

Engine exhaust retarder

The retarder capacity is increased by 30%, so faster speed is permitted on the downward slope. This improves safety and hauling performance.

Three-mode hydropneumatic suspension (optional)

To further enhance driving comfort, automatic three-mode suspension is optionally available. This enables the operator to select one of three cushioning effects (SOFT, NORMAL or HARD), depending on road conditions, for improved damping control.

ABS (Anti-lock brake System)

ABS is introduced to construction machinery first in the industry by Komatsu's outstanding electronics technology. This system prevents the tire lock under slippery condition while applying service brake and gives safety drive of the truck.

ROPS

This protects the operator and cab should the truck turn over. (Meets ISO 3471 and SAE J1040 APR88 ROPS standards.)



DIMENSIONS

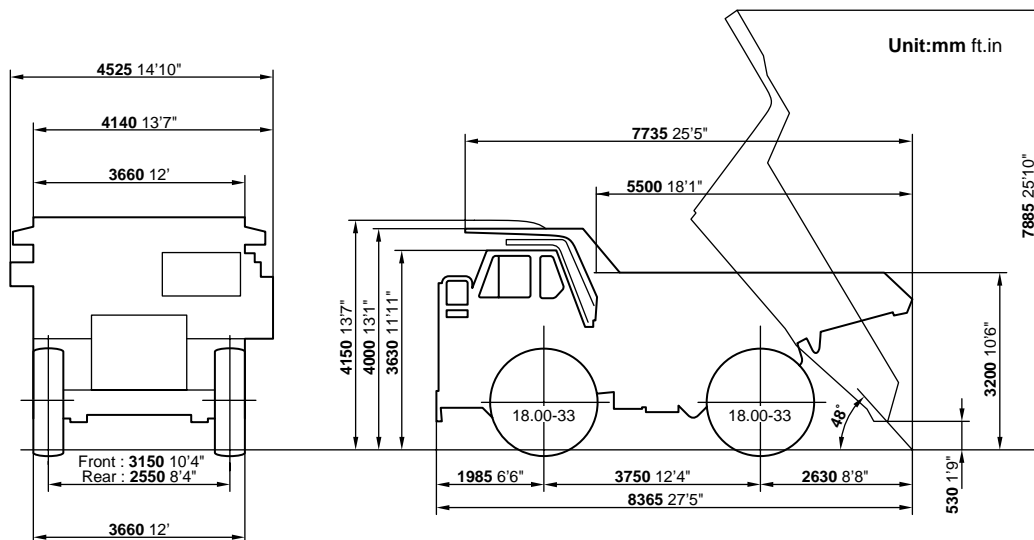

STANDARD EQUIPMENT

ENGINE:

- Alternator, 50 A
- Automatic idling setting system for engine low idle speed control
- Batteries, 2 x 12 V 170 Ah
- Engine, Komatsu SAA6D140E-3
- Mode switching system
- Starting motor, 1 x 11.0-kW

CAB:

- Cab, steel, sound suppression type

- Electronic display/monitoring system
- Mud guards (frame mounted, front)
- Seat belt, **50 mm 2"** width
- Seat, suspension type with reclining
- Steering wheel, tiltable & telescopic

LIGHTING SYSTEM:

- Back-up light
- Hazard light system

- Headlights with dimmer switch
- Stop and tail lights and turn signal lights

SAFETY:

- Back-up alarm
- Brakes
Emergency brake actuates all service brakes (front, rear and parking, 3-way)
- Catwalk with hand rails
- Coolant temperature alarm and light

- Front brake cut-off system
- Hand rails for platform
- Horn, air
- Ladders, LH and RH side
- Rear view mirrors

OTHERS:

- Electric circuit breaker, 24 V
- Hot area arrangement (-20°C thru +50°C)
- Side markers
- 18.00 - 33 - 28 PR tires



OPTIONAL EQUIPMENT

CAB:

- Air conditioner
- Ashtray and cigarette lighter
- Heater and defroster
- Radio, AM
- Radio, AM/FM with cassette
- Seat belt, **78 mm 3"** width
- Seat belt, **78 mm 3"** width for passenger seat
- Seat, fabric materials
- Seat, passenger
- Sun visor, additional
- Windows and windshield glass tinted safety glass

BODY:

- Body positioner
- Extensions, side walls, **200 mm 8"** [**570 kg 1,257 lb**]
- Rubber liners [**5200 kg 114,601 lb**]
- Spill guard, **150 mm 6"** [**90 kg 200 lb**]
- Spill guard, **250 mm 10"** [**145 kg 320 lb**]
- **24 m³ 31.4 yd³** rock body [**4250 kg 9,370 lb**]

- Liner [**4250 kg 9,370 lb**]

GUARD:

- Engine under guard [**25 kg 60 lb**]
- Platform guard, Right hand side [**35 kg 80 lb**]
- Propeller shaft guard, front [**15 kg 30 lb**]
- Propeller shaft guard, rear [**25 kg 60 lb**]
- Transmission under guard [**95 kg 210 lb**]

LIGHTING SYSTEM:

- Back-up lights, additional
- Fog lights
- Work light, RH and LH side

TIRES:

- 18.00 - 33 tires
- 18.00 R33 tires

SAFETY:

- Automatic slip regulation (ASR)
- Anti-lock brake system (ABS)
- Auto-retard speed control (ARSC)

- Emergency steering, automatic
- Retarder, engine exhaust
- Roll-over protective structure with FOPS [**850 kg 1,870 lb**]
- Roll-over protective structure [**770 kg 1,700 lb**]
- Under view mirror

ARRANGEMENT:

- Batteries for cold area arrangement
- Cold area arrangement (-30°C thru 40°C)
- Poor fuel (contained water) arrangement
- Sandy and dusty area arrangement

GAUGE:

- Dump position alarm & warning light
- Engine oil filter warning alarm and light
- Payload meter I printer type
- Payload meter II IC card type
- Revograph
- Revograph/Tachograph

- Tachograph

OTHERS:

- Air dryer
- Alcohol injector
- Alternator, 75 A
- Auto greasing system
- Centralized greasing
- Differential lock
- Engine side covers
- Fast fill coupler for fuel tank
- Fire extinguisher
- Gas charge tool
- Gas spring for engine hood
- Muffler (no body heating type)
- PM service connectors
- Pull hook, rear
- Radiator shutter, canvas type
- Spare parts for first service
- Tool kit
- Vandalism protection

[] shows the amount of increased weight

Standard equipment may vary for each country, and this specification sheet may contain attachments and optional equipment that are not available in your area. Please consult your Komatsu distributor for detailed information.

TRAVEL PERFORMANCE

To determine travel performance: Read from gross weight down to the percent of total resistance. From this weight-resistance point, read horizontally to the curve with the highest obtainable speed range, then down to maximum speed. Usable rimpull depends upon traction available and weight on drive wheels.

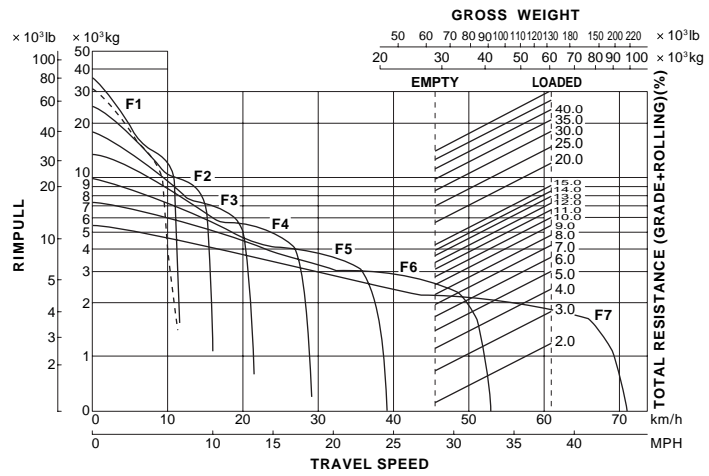

BRAKE PERFORMANCE

To determine brake performance: These curves are provided to establish the maximum speed and gearshift position for safer descents on roads with a given distance. Read from gross weight down to the percent of total resistance. From this weight-resistance point, read horizontally to the curve with the highest obtainable speed range, then down to maximum descent speed the brakes can safely handle without exceeding cooling capacity.

Grade distance: Continuous Descent

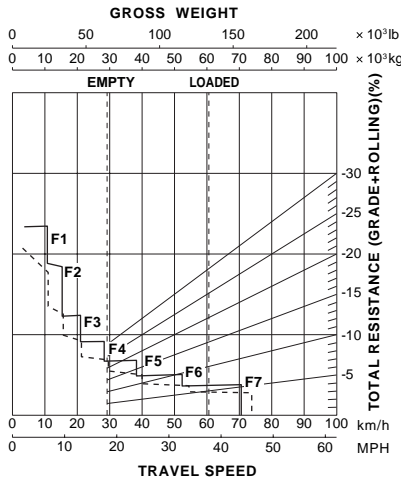

Grade distance: 450 m (1480 ft)

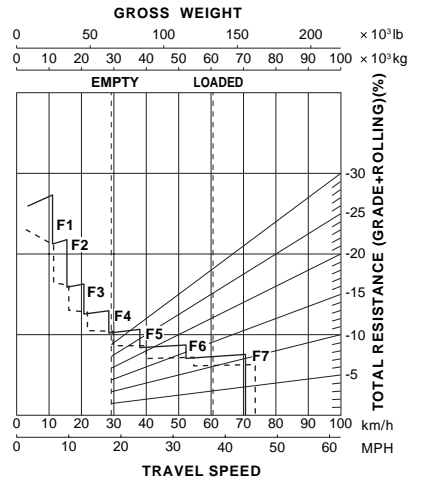

Grade distance: 600 m (1970 ft)

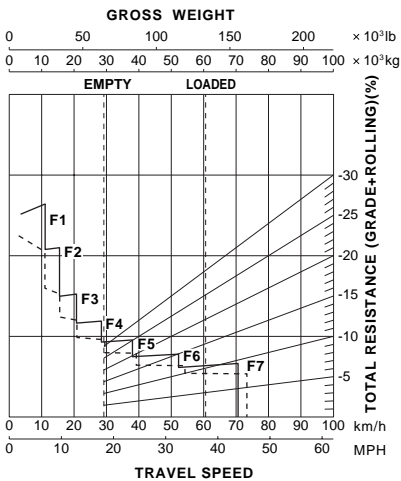

Grade distance: 900 m (2950 ft)

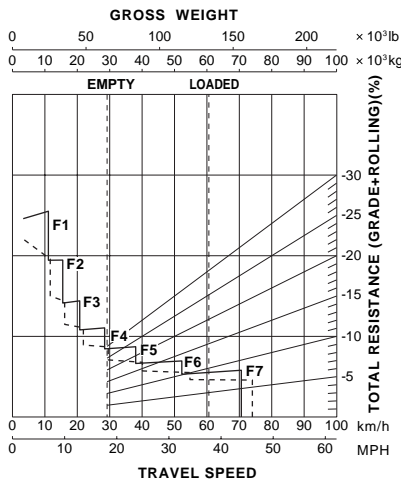

Grade distance: 1500 m (4920 ft)

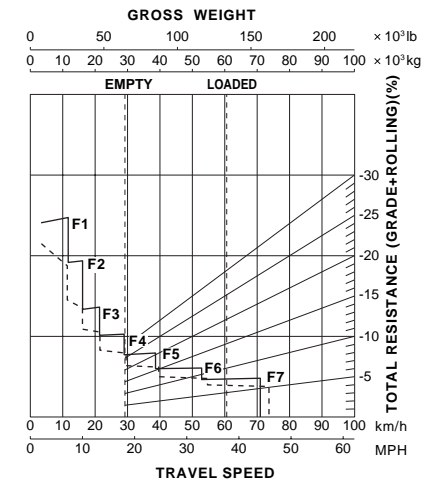

Performance line:

Solid lines...Exhaust retarder brake, additional (OPTION)

www.Komatsu.com

Printed in Japan 200412 IP.M.MY(15)



CEN00021-00

Materials and specifications are subject to change without notice. **KOMATSU** is a trademark of Komatsu Ltd. Japan.