



FL956F

Technical Features of FL956F:

- Equipped with Weichai WD10G220E23 engine as standard configuration and with Shangchai-SC11CB220G2B1 engine as optional;
- Adopted all-hydraulic flow priority to enlarge steering systems, light and flexible steering;
- Adopted large vision field, all closed damping cab, comfortable operation environment.



Products Information



Wheel Rim Mounting Nuts



Full Forged Integral Hydraulic Connector



24° cone seal pipe fitting



Hydraulic and Brake Systems

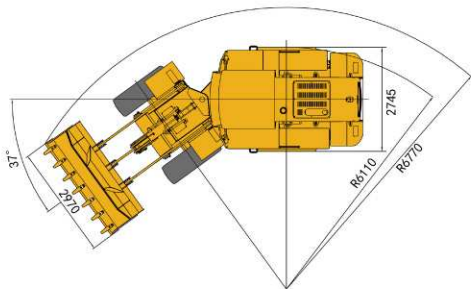
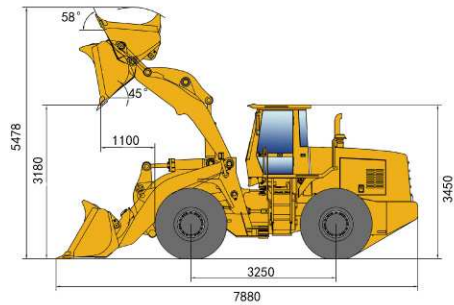

Main parameters

Rated load	kg	5000
Operating weight (standard)	kg	16500
Rated bucket capacity	m ³	3
Maximum breakout force	KN	165
Maximum traction force	KN	155
Total cycle time	s	10.6
Maximum dump height	mm	3180
Maximum dump distance	mm	1100
Forward speed range	km/h	0 ~ 38.4
Reverse speed range	km/h	0 ~ 24.2
Transport dimensions (L × W × H)	mm	7880X2970X3450
Maximum steering angle	°	37
Maximum gradeability	°	30
Minimum turning radius	mm	6770
Tire size	/	23.5-25-16PR

Engine parameters

Model	/	Weichai WD10G220E23
Type	/	6-cylinder, in-line, direct injection and turbocharged
Rated power/speed	kw/rpm	162/2000
Maximum torque	N·m	930
Cylinder diameter	mm	126
Stroke	mm	130
Displacement	L	9.756
Fuel consumption	g/kw·h	220

Hydraulic system

Work system pressure	Mpa	18
----------------------	-----	----

Braking System

Running braking system type	/	Single pipe air- oil 4-wheel clipper disc braking
Parking / emergency brake system type	/	Clipper disc braking

Tank Capacity

Fuel tank	L	280
Hydraulic oil tank	L	210