

PEL-JOB COMPACT EXCAVATOR

EB300



Pel-Job

SOLID AS A ROCK

COMPACT EXCAVATOR EB300 XT

Even more efficient !

Like all Pel-Job machines, the EB 300 develops an impressive level of performances. The bucket forces and digging depth are amongst the best on the market to give you improved productivity on all your sites.



Excellent equipment performances

The bucket has a very large range of movement: over 200°. This characteristic guarantees a good attack and square excavations at all depths.



Long chassis for more stability

The considerable length of the tracks provides exceptional stability and offers more output and safety, whilst reducing ground pressure.

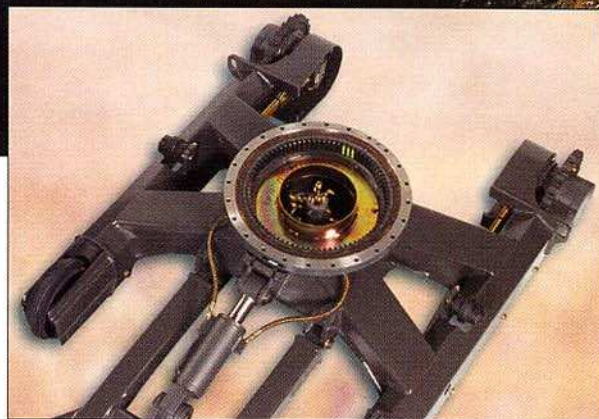

A new X-shaped undercarriage

This X shape makes for a better distribution of the loads on the side members, giving more rigidity and sturdiness. The top part of the side members slopes to prevent earth depositing itself there and to make it easier to clean.



Compact rear impact

The very compact dimensions of the new Pel-Job machines enable them to work safely on the narrowest sites. The wrap-



A sturdy top chassis

The double-yoke pivot multiplies the bearing surface on the chassis by two and enables a long pin to be fitted for a better distribution of stress and therefore less wear and less slackening.





protection

around shape of the counterweight provides the machine with excellent protection against all impacts.

The boom offset for working alongside a wall

The hydraulic offset of the boom makes it possible to reduce the overall dimensions of the excavator and to work alongside a wall.

Direct slewing crown wheel drive

This hydraulic motor drives the crown wheel directly, without a reduction gear. No wear and no play in the crown wheel drive, therefore no maintenance costs to allow for.



Smooth and very precise controls

The smoothness and precision of the power-assisted controls enable the most delicate work to be done quickly and well.

Pel-Job quick coupling

The exclusive Pel-Job quick coupling enables an accessory or a bucket to be hooked quickly without leaving the operator's cab. Unlocking can be either mechanical or hydraulic.

A VERY HIGH LEVEL OF COMFORT AND

COMPACT EXCAVATOR EB300 XT

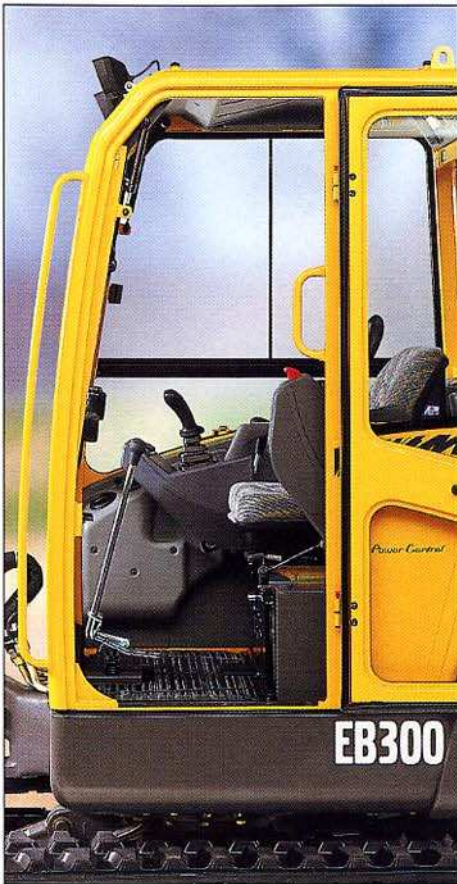

Safe access to the operator's cab

To facilitate access to the operator's cab, the cab door offers a wide opening, and the console swings up out of the way. The cab floor and step are non-slip and combined with two wide grab handles. To avoid any risk of an accident when the operator gets into or out of the cab, all of the machine's controls are locked when the left console is raised. This locking



also concerns the travel controls which are locked in the neutral position when the console is raised.



Excellent visibility

Thanks to the cab's very large glazed surface area, visibility all round the excavator is excellent. This is an important safety element for the property and people in the vicinity of the machine when it is in use, particularly on narrow or congested sites. The rounded contour and very compact shape of the engine cover also provides good visibility to the rear.



A vast and clear floor

The flat floor provides a considerable area for the feet. The translation levers are equipped with pedals to permit simultaneous control of the earthmoving equipment and of forward movement. The hydraulic accessory control pedal is positioned to the right so as not to hinder access. It folds away when it is not in use to provide more space.



A spacious and comfortable cab

The EB 300's cab offers incomparable comfort and operating quietness. Even tall operators immediately feel at ease in this generously sized cab.



Operator information

Placed within the operator's line of sight, the instrument panel groups together all the useful machine control information. An anti-theft keypad, available as an option, enables machine starting and the main hydraulic functions to be locked.

SAFETY



ergonomically-designed armrests

The short responsive manipulators avoid excessive operating movements and reduce fatigue. The position of the forearms resting on the ergonomically designed armrests permits very precise control of the manipulators.



Perfect accessibility of the hydraulics compartment

The control valves and all of the hydraulic components are located in a hydraulics compartment located on the side of the machine to facilitate access.

Exclusive to Pel-Job: the opening counterweight

This Pel-Job innovation permits excellent accessibility of the engine compartment whilst providing total protection to the rear of the machine thanks to the wrap-around shape of the counterweight.

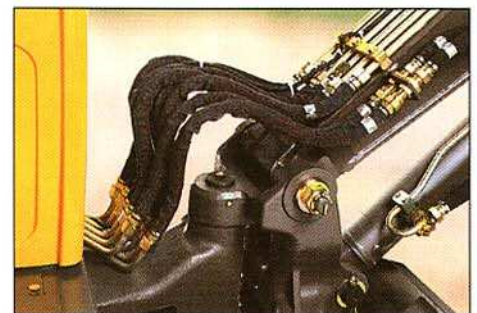

Loose fitting hoses at the base of the boom

All of the hoses which supply the boom are fitted loose, without going into the pivot, and are connected on the outside of the machine. They are thus subject to neither rubbing nor wear, and can easily be replaced if necessary.



FOPS 1, ROPS and TOPS protection

The EB 300's cab and canopy have a very high level of safety, guaranteed by the FOPS 1 (Falling Object Protection Structure), ROPS and TOPS (Roll and Tip Over Protection Structure) certifications. The seatbelt is part of the standard equipment.



ENGINE

Water-cooled Mitsubishi 3-cylinder diesel engine.

ModelS3L2
Gross power, rated (ISO 9249) ..20 kW (27.2 hp) at 2800 r/min
Power, installed (ISO 9249)17.8 kW (24.2 hp) at 2400 r/min
Displacement, total1318 cc
Maximum torque (ISO 9249)77 Nm at 1600 r/min
Bore x stroke.....78 mm x 92 mm



ELECTRICAL SYSTEM

Rated voltage12 V
Battery capacity12 V - 70 Ah
Alternator rating12 V - 50 A
Starter motor output.....12 V - 2 kW



HYDRAULIC SYSTEM

Variable flow Power Control hydraulic system. The oil flow is continuously adapted to suit the forces required for a better use of the engine's power.

Controlpower-assisted hydraulic controls

Variable displacement double pump for the equipment (boom, dipper and bucket) and travel circuits:

Maximum flow2 x 23.3 l/min
Maximum operating pressure25 MPa (250 bars)

Gear pump for the slewing, offset and blade circuits:

Maximum flow19.4 l/min
Maximum operating pressure21 MPa (210 bars)

Double-acting hydraulic circuit for accessories:

Maximum flow46.6 l/min
Maximum operating pressure25 MPa (250 bars)



BUCKET PERFORMANCE

Breakout force2420 daN
Tearout force1720 daN



SLEWING SYSTEM

Turntable slewing is provided by a radial piston hydraulic motor which drives directly (without a reduction gear) a ball internal crown wheel with remote lubrication:

Slewing speed10 r/min
Turntable brakingautomatic multi-disc brake
Absorption of hydraulic shocks.....Hydrosensor shockless valve



UNDERCARRIAGE

The undercarriage is made up of an "X" box fabricated centre part for more rigidity and of sloping side members for a better clearance of materials. The rollers and the tensioning wheels are lubricated for life.

Bottom/top rollers per side.....3 / 1
Track width300 mm
Track tensionby grease piston
Blade (width x height)1530 x 340 mm



DRIVETRAIN

Each track is driven by an axial piston hydraulic motor equipped with two speeds and an epicyclic reduction gear.

Max. speed (low speed/ high speed)2.1 km/h / 3.6 km/h
Max. tractive force2750 daN

The forward movement control is automatically locked when the operator raises the left console.



SERVICE FILL CAPACITIES

Fuel tank49 l
Hydraulic tank21 l
Hydraulic system, total.....48 l
Engine oil5.2 l
Cooling system6 l



WEIGHT

Operational weight and ground pressure:

	Rubber Tracks	Steel Tracks
Canopy version	2964 kg 0.31 kg/cm ²	3025 kg 0.32 kg/cm ²
cab version	3090 kg 0.32 kg/cm ²	3151 kg 0.33 kg/cm ²



NOISE LEVELS

Results of dynamic measurements:

Noise level exterior (LwA)95 dB(A)
Noise level in the cab (LpA)82 dB(A)
Noise level under the canopy (LpA)80 dB(A)

The noise levels conform to directive n° 86/662 EEC and its amendments.

DIMENSIONS

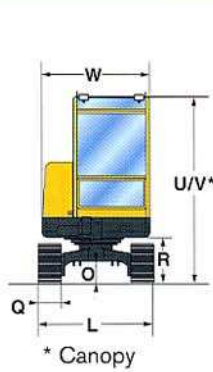
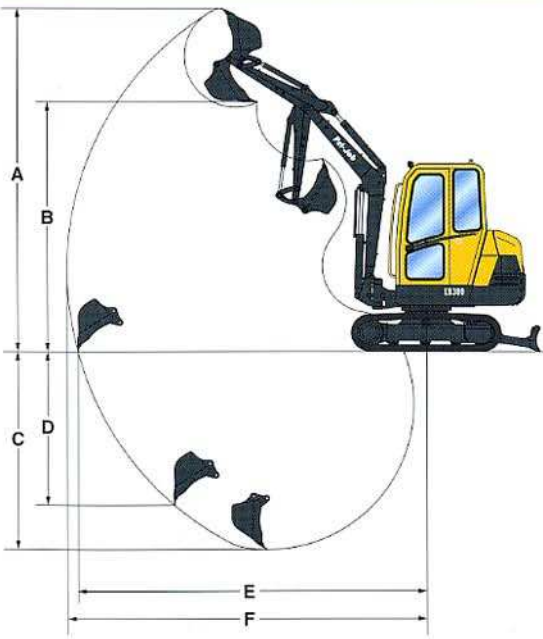



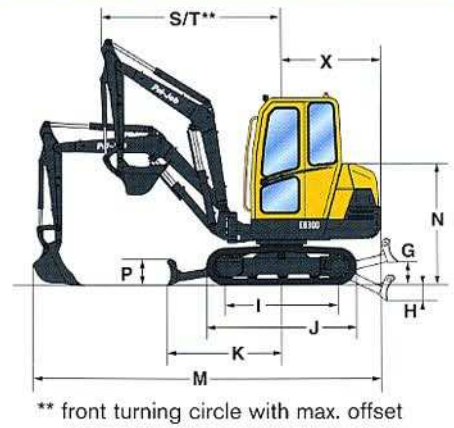



* Canopy



** front turning circle with max. offset

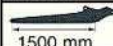

Buckets	 Width	 Weight	 Capacity
Backhoe buckets 	250 mm	40 kg	35 l
	300 mm	46 kg	37 l
	400 mm	55 kg	55 l
	450 mm	60 kg	65 l
	500 mm	66 kg	73 l
	600 mm	75 kg	91 l
Ditch bucket 	750 mm	84 kg	119 l
	1300 mm	102 kg	139 l

Dipper	A	B	C*	C	D	E	F
 1200 mm	4450	3250	3030	2740	2150	4620	4740
 1500 mm	4640	3430	3330	3040	2440	4910	5030

* Dig depth with blade down.



G	H	I	J	K	L	M	N	O
390	520	1440	1910	1450	1480	4370	1550	280

P	Q	R	S	T	U	V	W	X
340	300	570	1950	1530	2390	2340	1420	1260

(mm)

TOTAL ROTATION LOAD CAPACITIES (CAB VERSIONS)

These capacities are given for a machine without a bucket or quick-release coupling and fitted with rubber tracks for a 360° total rotation lifted load. The handling capacity is 75% of the tipping load or 87% of the hydraulic limit. Caution: the load lifted must not exceed 1000 kg on a machine not fitted with a safety valve on the boom ram, in accordance with EN standard 474-5.

Outreach		1.50 m	2.00 m	2.50 m	3.00 m	3.50 m	4.00 m	4.30 m
 1200 mm	Z2		1030	745	575	460	380	
	Z1	1520*	970	705	550	450	380	
	Z3	1595	990	710	555			
 1500 mm	Z2		1055	755	580	465	380	
	Z1	880*	965	695	540	440	370	335
	Z3	1570	975	700	545	445		

* hydraulic limit

(kg)

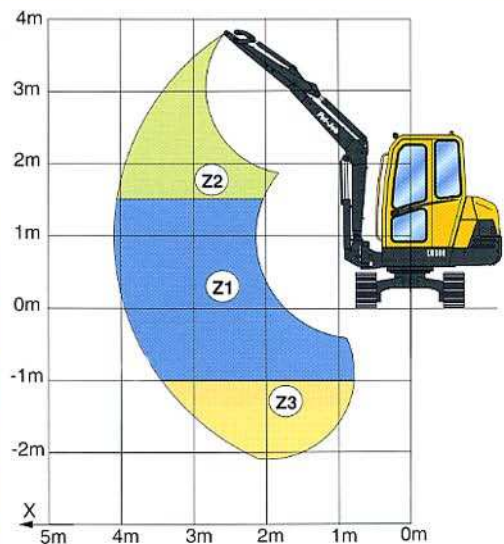

STANDARD EQUIPMENT

Engine

Dry-type air filter.
Electric pre-heating device.
Transparent diesel oil filter, pre-filter and sediment chamber.
Purge plug under the diesel oil tank.
Oil sump sheet metal guard.
Continuous adjustment of engine speed.

Electrical system

12 V - 70 Ah battery.
Horn.
12 V power socket for inspection lamp.

Undercarriage

300 mm wide rubber tracks.
Dozer blade.
Towing and anchoring rings.
Remote lubrication of the slewing crown ring.

Hydraulic system

ISO power-assisted hydraulic controls.
Additional double-acting hydraulic control valve for an attachment circuit with folding control pedal and circuit for direct return of oil to the hydraulic tank.
Attachment circuit piping (double-acting + return) as far as the bottom of the boom.
Power-assisted control of the hydraulic offset of the boom by

the left control lever.
Control of forward movement by two levers coupled to pedals.

Cab (cab version)

Level 1 FOPS (Falling Objects Protective Structure).
TOPS (Tip-Over Protective Structure).
ROPS (Roll-Over Protective Structure).
Fabric-covered multi-adjustable sprung seat.
Non-slip floor and grab handle for access to the driver's cab.
Seatbelt.
Cab mounted on rubber mountings.
Two working lights.
Two-speed heating and ventilation.
Cab heating adjustment.
Front window with opening system power-assisted by two gas rams.
Sliding window (right).
Door stops.
Provision for a radio (location for a radio and two speakers, aerial and electric wiring already fitted).
Interior lighting.
Anti-corrosion protection of the cab by electrophoresis.
Windscreen wiper and washer (front).
Emergency exit via the rear window.

Canopy (Canopy version)

Level 1 FOPS (Falling Objects Protective Structure).
TOPS (Tip-Over Protective Structure).
ROPS (Roll-Over Protective Structure).
Vinyl-covered multi-adjustable sprung seat.
Non-slip floor and grab handle for access to the driver's cab.
Seat belt.
Working light on the canopy frame.

Instrumentation and monitoring

Monitoring and warning light for: pre-heating, engine oil pressure, water temperature, battery charging, hydraulic filter restriction, air filter restriction.
Fuel gauge.
Hour meter.
Device for automatic switching off of engine in the event of overheating or drop in oil pressure.

Working equipment

2300 mm long monobloc boom.
1200 mm dipper.
140° hydraulic boom offset.
Cushion on the boom ram.
Handling equipment for a load less than 1000 kg (hooking device on the bucket rod and load table displayed in the driver's cab).

Remote lubrication of the bottom of the offset ram.

Safety

Device for locking the earth-work equipment's controls and the travel levers when the left console is raised to gain access to the driver's cab.
Engine starting safety device: the left console must be raised to operate the starter.
Pressure accumulator on the power assistance circuit in order to be able to put the equipment on the ground if the engine is switched off.
Window-breaker hammer (cab).
Key-lockable toolbox.

Official approval

Machine conforming to directive n° 98/37 EEC and its amendments.
Soundproofing conforming to directive n° 86/662 EEC and its amendments.
Handling device conforming to EN standard 474-5.
FOPS 1 conforming to ISO standard 3449.
TOPS conforming to ISO standard 12117.
Electromagnetic compatibility (EMC) conforming to directive n° 89/336 EEC and its amendments.

OPTIONAL EQUIPMENT

Working equipment

Long dipper (1500 mm).
Safety valve piloted by the power assistance circuit on the boom ram with overload indicator (for handling loads over 1000 kg).
Safety valve on the dipper ram.
Mechanically-controlled quick-change attachment coupling.
Hydraulically-controlled quick-change attachment coupling.

Hydraulic circuits for attachments

Circuit for hydraulic breaker with direct return to the tank.
Hydraulic circuit for double-acting attachments.
Hydraulic circuit for operating a clam-shell bucket (opening/closing and rotation of the bucket).

Undercarriage

Steel tracks (300 mm wide).

Lighting

Additional working light on the boom.
Additional rear working light.
Revolving light.

Environmental protection

Bio-degradable hydraulic oil.
Catalytic exhaust.

Comfort and safety

Radio (cab).

Anti-theft system (2 programmable codes).
Electric circuit-breaker.
Rear wind-cutter protection on canopy.

Service and maintenance

Tool kit.

Miscellaneous

Special customised paint (RAL specifications).

Volvo Construction Equipment Group

Ecomat Industrie S.A.
Avenue Charles de Gaulle
BP 119 - F - 01303 Belley Cedex
Tél. : +33 (0)4 79 81 15 09
Fax : +33 (0)4 79 81 39 63

Under our policy of continuous product improvement, we reserve the right to change specifications and design without prior notice. The illustrations do not necessarily show the standard version of the machine.

Ref. No. KON 2907866
CST 21 3 432 1016
Printed in France 06.99 N English