

**SAMSUNG EXCAVATOR**

# **SE280LC-3 SE280NLC-3**

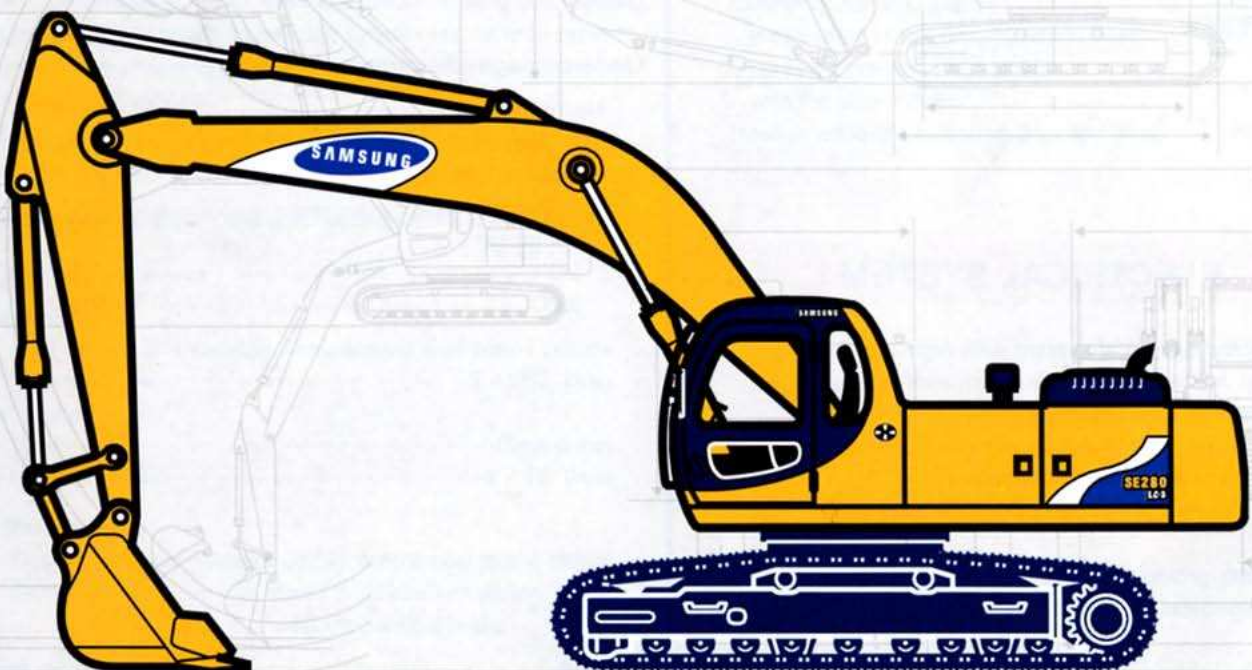

- **Engine power, gross:**  
**160 kW (215 hp)**
- **Operating weight:**
  - LC : 27.8~29.6 t
  - NLC : 27.7~29.5 t
- **Buckets (SAE):**  
**780~1600 l**
- Low-emission, turbocharged Cummins diesel engine with direct injection
- Integrated mode selection system and electronically controlled system (ACS)
- 2 variable displacement axial piston pumps. Independent and simultaneous movements of the digging equipment is controlled by "Automatic sensing work mode".
- Cab
  - Ergonomic environment
  - Low sound level
  - Filtered air
  - Hydraulic dampening mounts
- Rugged digging equipment produced by robot welding
- High lifting, breakout and tearout forces for tough digging conditions
- Undercarriage
  - LC : Long undercarriage for good stability
  - NLC : Narrow width for easy transportation
- Prepared for a number of optional items of equipment

**SAMSUNG**



## ENGINE

The engine is a low-emission, turbocharged, 4-stroke diesel engine with water cooling, direct injection and aftercooler, specially developed for excavator use.

The machine can work at any job site, contributing to good fuel economy, low sound level, less wear and longer life.

**Air Filter:** 2-stage

**Automatic Idling System:** Reduces the engine speed to an idling speed when levers and pedals are not activated.

Maker .....	CUMMINS
Model .....	C8.3-C
Power output at .....	35 r/s (1900 rpm)
Net (ISO 9249/DIN 6271) .....	147 kW (200 ps / 197 hp)
Gross (SAE J1349) .....	160 kW (218 ps/ 215 hp)
Max. torque .....	87 kg·m at 1300 rpm
No. of cylinders .....	6
Displacement .....	8.27 l
Bore .....	114 mm
Stroke .....	135 mm



## ELECTRICAL SYSTEM

Well-protected electrical system with high capacity.

Double lock harness plugs are waterproof to ensure secure connections and prevent corrosion

The relays and solenoid valves are shielded to prevent accidental damage or terminal contact

Master Switch for battery disconnect is standard.

**ACS system**, providing integrated mode selection function and self-diagnostic mode, is standard.

Voltage .....	24 V
Batteries .....	2 × 12 V
Battery capacity .....	200 Ah
Alternator .....	24 V / 50 A



## SERVICE REFILL CAPACITIES

Fuel tank .....	470 l
Hydraulic system, total .....	332 l
Hydraulic tank .....	200 l
Engine oil .....	25.5 l
Engine coolant .....	26.5 l
Swing reduction unit .....	11.0 l
Travel reduction unit .....	2 × 5.5 l



## SWING SYSTEM

The superstructure is swung by means of an axial piston motor and a planetary gearbox. Automatic swing holding brake and anti-rebound valve are standard.

Max. swing speed ..... 10.8rpm



## UNDERCARRIAGE

Undercarriage with robust X-shape frame.

Sealed and grease-lubricated track chain is standard.

**Undercarriage alternatives:** LC/NLC

No. of track pads .....	2 × 50
Link pitch .....	203.2 mm
No. of lower track roller .....	2 × 9
No. of carrier roller .....	2 × 2
Track gauge	
LC .....	2590 mm
NLC .....	2390 mm



## DRIVE

Each track is powered by an automatic two speed travel motor.

The track brakes are of the multi-disc type, spring-applied and hydraulic released.

Travel motor, brake and planetary gears are well protected in the track frame.

Max. tractive effort .....	230.5 kN
	(23.5 ton)
Max. travel speed(1st/2nd) .....	3.3/5.2 km/h
Gradeability .....	35° (70 %)



## HYDRAULIC SYSTEM

The hydraulic system, named "Automatic Sensing Work Mode," is designed for high productivity, high digging capacity, high maneuvering precision and good fuel economy.

The summation system, boom priority, arm priority and regeneration system of boom and arm flow are provided for the best operation.

**The following important functions are included in the system ;**

**Summation system:** Providing full use of the pump oil flow.

**Boom priority:** Supplying priority to boom operation for fast raising in the application of loading and deep excavation.

**Arm priority:** providing priority to arm operation for faster cycle times at leveling work and for increased bucket filling factor at digging operation.

**Regeneration system:** Enhancing cylinder life cycle to prevent cavitation and providing priority to other movements in simultaneous operation.

**Power boost:** All digging, lifting and tractive forces are increased.

**Holding valves:** Boom and arm holding valves are standard.

### Pumps

#### Main pump :

Type .....2 × Variable displacement axial piston pumps

Maximum flow .....2 × 250 l/min

#### Pilot pump :

Type .....Gear pump

Maximum flow .....1 × 19 l/min

### Hydraulic motors

Travel .....Variable displacement axial piston motor

Swing .....Fixed displacement piston motor  
with mechanical brake

### Relief valve setting

Implement .....31.4/34.3 MPa (320/350 kg/cm<sup>2</sup>)

Travel circuit .....34.3 MPa (350 kg/cm<sup>2</sup>)

Swing circuit .....26.5 MPa (270 kg/cm<sup>2</sup>)

Pilot circuit .....3.4 MPa (35 kg/cm<sup>2</sup>)

### Hydraulic cylinders

Boom .....2  
bore × stroke ..... Ø 140 mm × 1480 mm

Arm .....1  
bore × stroke ..... Ø 150 mm × 1745 mm

Bucket .....1  
bore × stroke ..... Ø 140 mm × 1140 mm



## CAB

Easily accessible cab with wide door opening. Lined with sound-absorbing material.

The cab is supported by hydraulic dampening mounts to reduce shock and vibration. All-around visibility. The front windshield can slide up into the ceiling and the lower front glass can be removed.

**Integrated air conditioning and heating system:** Pressurized and filtered cab air is supplied by a 4-speed fan. The air is distributed via 8 vent holes.

**Ergonomic operator's seat:** The adjustable seat and control consoles move independently to best accommodate the operator. The seat has eight different adjustments and seat belt to meet any operator's requirement.

**Sound Level:** Approved according to Directive 86/662/EEC.

Exterior noise (ISO 6395)

mean value of L<sub>WA</sub> (sound power level) 105 dB(A)

Operator's position (ISO 6396)

with the door closed

mean value of L<sub>PA</sub> (sound pressure level) 78 dB(A)



## GROUND PRESSURE

● Machine with 6.2 m boom, 3.05 m arm, 1240 l (975 kg) bucket and 4800 kg counterweight.

LC

Description	Shoe width	Operating weight	Ground pressure	Overall width
Triple grouser	600 mm	27800 kg	52.0 kPa (0.53 kg/cm <sup>2</sup> )	3190 mm
	700 mm	28410 kg	46.1 kPa (0.47 kg/cm <sup>2</sup> )	3290 mm
	800 mm	28750 kg	40.2 kPa (0.41 kg/cm <sup>2</sup> )	3390 mm
	900 mm	29130 kg	36.3 kPa (0.37 kg/cm <sup>2</sup> )	3490 mm
Swamp shoe	900 mm	28800 kg	36.3 kPa (0.37 kg/cm <sup>2</sup> )	3490 mm

NLC

Description	Shoe width	Operating weight	Ground pressure	Overall width
Triple grouser	600 mm	27700 kg	52.0 kPa (0.53 kg/cm <sup>2</sup> )	2990 mm
	700 mm	28310 kg	46.1 kPa (0.47 kg/cm <sup>2</sup> )	3090 mm
	800 mm	28650 kg	40.2 kPa (0.41 kg/cm <sup>2</sup> )	3190 mm
	900 mm	29030 kg	36.3 kPa (0.37 kg/cm <sup>2</sup> )	3290 mm
Swamp shoe	900 mm	28700 kg	36.3 kPa (0.37 kg/cm <sup>2</sup> )	3290 mm

● Machine with 6.2 m boom, 3.05 m arm, 1240 l (975 kg) bucket and 5400 kg counterweight.

LC

Description	Shoe width	Operating weight	Ground pressure	Overall width
Triple grouser	600 mm	28280 kg	53.0 kPa (0.54 kg/cm <sup>2</sup> )	3190 mm
	700 mm	28890 kg	47.1 kPa (0.48 kg/cm <sup>2</sup> )	3290 mm
	800 mm	29230 kg	41.2 kPa (0.42 kg/cm <sup>2</sup> )	3390 mm
	900 mm	29610 kg	37.3 kPa (0.38 kg/cm <sup>2</sup> )	3490 mm
Swamp shoe	900 mm	29280 kg	37.3 kPa (0.38 kg/cm <sup>2</sup> )	3490 mm

NLC

Description	Shoe width	Operating weight	Ground pressure	Overall width
Triple grouser	600 mm	28180 kg	53.0 kPa (0.54 kg/cm <sup>2</sup> )	3190 mm
	700 mm	28790 kg	47.1 kPa (0.48 kg/cm <sup>2</sup> )	3290 mm
	800 mm	29130 kg	41.2 kPa (0.42 kg/cm <sup>2</sup> )	3390 mm
	900 mm	29510 kg	37.3 kPa (0.38 kg/cm <sup>2</sup> )	3490 mm
Swamp shoe	900 mm	29180 kg	37.3 kPa (0.38 kg/cm <sup>2</sup> )	3490 mm

## BUCKET & ARM COMBINATION

● Machine with 6.2 m boom and 4800 kg (5400 kg) counterweight.

LC

Bucket		Narrow Bucket	Standard Bucket	Reinforced Bucket	Wide Bucket
Bucket capacity (SAE / CECE)		780 / 700 l	1240 / 1100 l	1240 / 1100 l	1600 / 1400 l
Bucket width (with / with side cutters)		956 / 846 mm	1361 / 1251 mm	1361 / 1251 mm	1651 / 1541 mm
Weight (without side cutters)		785 kg	975 kg	1065 kg	1120 kg
No. of teeth		4	5	5	6
Application		Trenching	General Purpose	Extreme Service	Loading Service
Arm options	2.55 m	○(○)	○(○)	○(○)	□(○)
	3.05 m	○(○)	○(○)	○(○)	□(□)
	4.0 m	○(○)	○(○)	□(□)	△(□)

- : Applicable for general purpose up to 2000 kg/m<sup>3</sup>
- : Applicable for light duty up to 1600 kg/m<sup>3</sup>
- △ : Applicable for light duty up to 1100 kg/m<sup>3</sup>
- × : Not usable.

● Machine with 6,2 m boom and 4800 kg (5400 kg) counterweight.

NLC

Bucket		Narrow Bucket	Standard Bucket	Reinforced Bucket	Wide Bucket
Bucket capacity (SAE / CECE)		780 / 700 l	1240 / 1100 l	1240 / 1100 l	1600 / 1400 l
Bucket width (with / without side cutters)		956 / 846 mm	1361 / 1251 mm	1361 / 1251 mm	1651 / 1541 mm
Weight (with side cutters)		785 kg	975 kg	1065 kg	1120 kg
No. of teeth		4	5	5	6
Application		Trenching	General Purpose	Extreme Service	Loading Service
Arm options	2.55 m	○(○)	○(○)	□(□)	△(□)
	3.05 m	○(○)	□(□)	□(□)	△(□)
	4.0 m	○(○)	□(□)	△(□)	×(△)

- : Applicable for general purpose up to 2000 kg/m<sup>3</sup>
- : Applicable for light duty up to 1600 kg/m<sup>3</sup>
- △ : Applicable for light duty up to 1100 kg/m<sup>3</sup>
- × : Not usable.

## DIMENSIONS

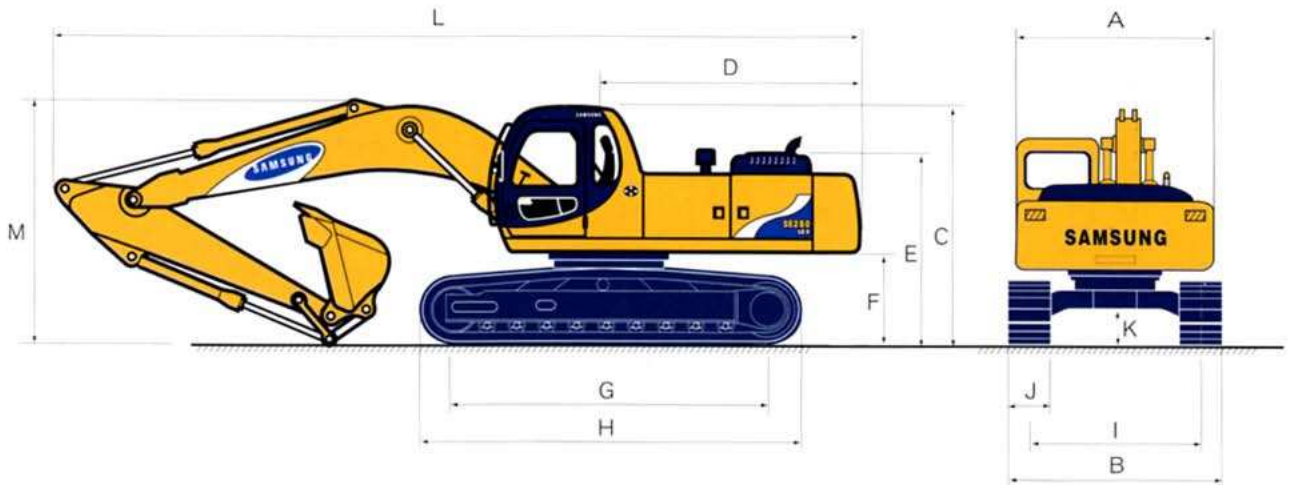

Description	unit	SE280LC-3			SE280NLC-3		
		2.55m Arm	3.05m Arm	4.0m Arm	2.55m Arm	3.05m Arm	4.0m Arm
A. Overall width of upper structure	mm	2840	2840	2840	2840	2840	2840
B. Overall width	mm	3190	3190	3190	2990	2990	2990
C. Overall height of cab	mm	3030	3030	3030	3030	3030	3030
D. Tail swing radius	mm	3150	3150	3150	3150	3150	3150
E. Overall height of engine hood	mm	2435	2435	2435	2435	2435	2435
F. * Counterweight clearance	mm	1125	1125	1125	1125	1125	1125
G. Tumbler length	mm	4015	4015	4015	4015	4015	4015
H. Track length	mm	4870	4870	4870	4870	4870	4870
I. Track gauge	mm	2590	2590	2590	2390	2390	2390
J. Shoe width	mm	600	600	600	600	600	600
K. * Min. ground clearance	mm	480	480	480	480	480	480
L. Overall length	mm	10760	10660	10710	10760	10660	10710
M. Overall height of boom	mm	3370	3200	3620	3370	3200	3620

\* Without shoe grouser

### Boom

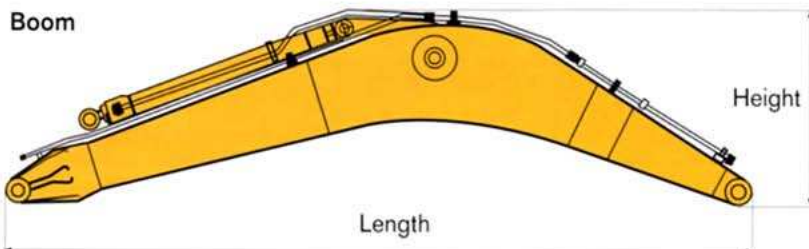

Description	6.2 m
Length	6430 mm
Height	1680 mm
Width	770 mm
Weight *	2470 kg

\* Includes cylinder, pin and piping

### Arm

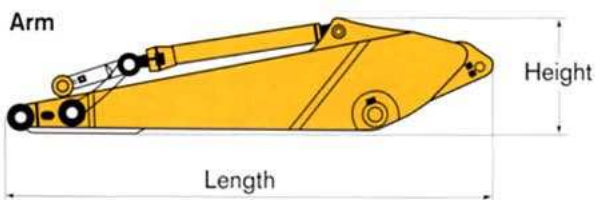

Description	2.55 m	3.05 m	4.0 m
Length	3710 mm	4150 mm	5100 mm
Height	965 mm	965 mm	1025 mm
Width	545 mm	545 mm	545 mm
Weight *	1413 kg	1489 kg	1708 kg

\* Includes cylinder, piping and linkage

## WORKING RANGES

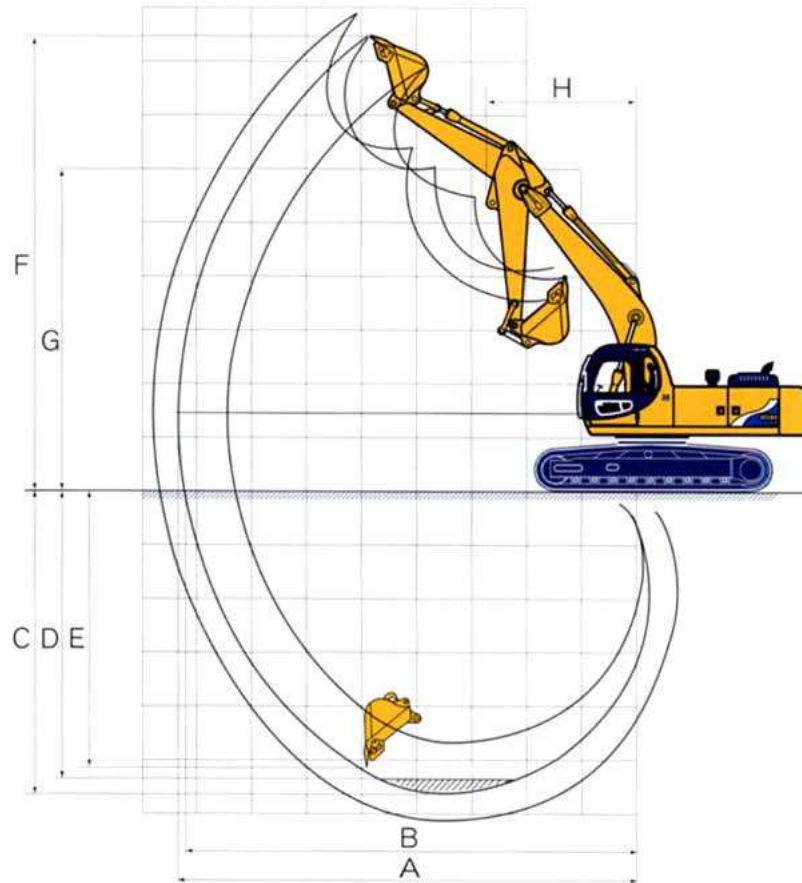

Description	unit	SE280LC-3			SE280NLC-3		
		2.55m Arm	3.05m Arm	4.0m Arm	2.55m Arm	3.05m Arm	4.0m Arm
A. Max. digging reach	mm	10160	10690	11575	10160	10690	11575
B. Max. digging reach on ground	mm	9955	10495	11400	9955	10495	11400
C. Max. digging depth	mm	6850	7350	8300	6850	7350	8300
D. Max. digging depth (8' level)	mm	6605	7160	8150	6605	7160	8150
E. Max. vertical wall digging depth	mm	5350	6255	7025	5350	6255	7025
F. Max. cutting height	mm	9610	10020	10445	9610	10020	10445
G. Max. dumping height	mm	6670	7030	7450	6670	7030	7450
H. Min. front swing radius	mm	4170	4130	4245	4170	4130	4245

Digging forces with direct fit GP bucket:	unit	2.55m Arm	3.05m Arm	4.0m Arm	2.55m Arm	3.05m Arm	4.0m Arm
Bucket radius	mm	1600	1600	1600	1600	1600	1600
Breakout force (Normal / Power boost)	kN (ton)	158 / 172 (16.1 / 17.6)	158 / 172 (16.1 / 17.6)	158 / 172 (16.1 / 17.6)	158 / 172 (16.1 / 17.6)	158 / 172 (16.1 / 17.6)	158 / 172 (16.1 / 17.6)
Tearout force (Normal / Power boost)	kN (ton)	147 / 161 (15.0 / 16.4)	123 / 135 (12.6 / 13.8)	102 / 112 (10.4 / 11.4)	147 / 161 (15.0 / 16.4)	123 / 135 (12.6 / 13.8)	102 / 112 (10.4 / 11.4)
Rotation angle, bucket	°	179°	179°	179°	179°	179°	179°

Counterweight: 4800 kg / 5400 kg













Max. permitted buckets for direct fit:	unit	2.55m Arm	3.05m Arm	4.0m Arm	2.55m Arm	3.05m Arm	4.0m Arm
GP bucket 1.5 t/m <sup>3</sup>	l	1500/1600	1400/1500	1200/1300	1400/1600	1200/1300	1000/1100
GP bucket 1.8 t/m <sup>3</sup>	l	1300/1400	1200/1300	1000/1100	1200/1300	1100/1200	900/1000
RB bucket 1.8 t/m <sup>3</sup>	l	1200/1300	1100/1200	950/1000	1100/1200	1000/1100	900/950
RB bucket 2.0 t/m <sup>3</sup>	l	1100/1200	1000/1100	900/950	1000/1100	900/1000	800/900

## LIFTING CAPACITY (At the arm end without bucket)

*Note: For lift capacity including bucket, simply subtract actual weight of bucket from the following values.*

**SE280LC-3 (Shoe 600 mm, Counterweight 4800 kg)**

unit : kg, mm

 Across under-carriage  Along under-carriage	Lifting hook related to ground level	3 m		4.5 m		6 m		7.5 m		Max.reach		
												Max. mm
Boom 6.2 m + Arm 2.55 m	6 m					*6900	*6900	5170	*6730	5130	*6730	7537
	4.5 m			*9700	*9700	7170	*7820	5070	*6980	4400	*6850	8173
	3 m			10250	*12390	6780	*9030	4890	*7540	4040	6450	8496
	1.5 m			9650	*14240	6450	*10100	4720	7650	3910	6300	8542
	0 m			9450	*14760	6260	10520	4610	7520	4000	6480	8317
	-1.5 m	*11480	*11480	9450	*14400	6200	10460	4580	7500	4360	7100	7796
	-3 m	*17940	*17940	9590	*13230	6280	*9990			5210	*8340	6911
	-4.5 m	*14320	*14320	9920	*10680					7440	*8530	5484
Boom 6.2 m + Arm 3.05 m	6 m							5240	*6130	4540	*5550	8133
	4.5 m					*7230	*7230	5100	*6520	3960	*5530	8725
	3 m			10460	*11410	6840	*8500	4900	*7160	3660	*5710	9028
	1.5 m			9740	*13590	6470	*9700	4710	7640	3550	5730	9071
	0 m			9410	*14560	6230	*10490	4560	7480	3610	5870	8860
	-1.5 m	*10510	*10510	9340	*14540	6130	10380	4500	7410	3890	6340	8374
	-3 m	*17470	*17470	9430	*13700	6160	*10270	4570	7480	4520	7410	7558
	-4.5 m	*16120	*16120	9690	*11710	6370	*8560			6000	*7950	6283
Boom 6.2 m + Arm 4.0 m	6 m							*5130	*5130	3760	*3960	9116
	4.5 m							5190	*5640	3340	*3960	9646
	3 m			*9470	*9470	7000	*7390	4950	*6370	3110	*4060	9921
	1.5 m			9990	*12090	6550	*8780	4710	*7150	3010	*4300	9960
	0 m	*6480	*6480	9420	*13780	6210	*9860	4510	7440	3050	*4700	9768
	-1.5 m	*9670	*9670	9180	*14420	6020	10280	4380	7300	3230	5310	9330
	-3 m	*14110	*14110	9160	*14190	5960	10220	4360	7270	3630	5980	8608
	-4.5 m	*18760	*18760	9310	*13010	6060	*9670	4480	*7170	4460	*7140	7517

- Notes : 1. The above loads are in compliance with SAE and ISO Hydraulic Excavator Lift Capacity Standards.  
 2. Rated loads do not exceed 87% of hydraulic lifting capacity or 75% of tipping load.  
 3. Rated loads marked with an asterisk (\*) are limited by hydraulic capacity rather than tipping load.















## LIFTING CAPACITY (At the arm end without bucket)

*Note: For lift capacity including bucket, simply subtract actual weight of bucket from the following values.*

**SE280LC-3 (Shoe 600 mm, Counterweight 5400 kg)**

unit : kg, mm

 Across under-camage  Along under-camage	Lifting hook related to ground level	3 m		4.5 m		6 m		7.5 m		Max.reach		Max. mm
												
Boom 6.2 m + Arm 2.55 m	6 m					*6900	*6900	5480	*6730	5440	*6730	7537
	4.5 m			*9700	*9700	7580	*7820	5380	*6980	4680	*6850	8173
	3 m			10860	*12390	7190	*9030	5200	*7540	4310	6790	8496
	1.5 m			10260	*14240	6870	*10100	5030	8040	4180	6630	8542
	0 m			10060	*14760	6670	*10720	4920	7920	4280	6830	8317
	-1.5 m	*11480	*11480	10060	*14400	6620	*10750	4900	7890	4660	7480	7796
	-3 m	*17940	*17940	10200	*13230	6700	*9990			5550	*8340	6911
	-4.5 m	*14320	*14320	10530	*10680					7910	*8530	5484
Boom 6.2 m + Arm 3.05 m	6 m							5550	*6130	4820	*5550	8133
	4.5 m					*7230	*7230	5410	*6520	4220	*5530	8725
	3 m			11070	*11410	7260	*8500	5220	*7160	3900	*5710	9028
	1.5 m			10350	*13590	6890	*9700	5020	*7810	3790	6040	9071
	0 m			10020	*14560	6640	*10490	4880	7880	3870	6180	8860
	-1.5 m	*10510	*10510	9950	*14540	6540	*10720	4810	7810	4160	6680	8374
	-3 m	*17470	*17470	10040	*13700	6580	*10270	4880	*7790	4830	*7690	7558
	-4.5 m	*16120	*16120	10300	*11710	6790	*8560			6390	*7950	6283
Boom 6.2 m + Arm 4.0 m	6 m							*5130	*5130	*3960	*3960	9116
	4.5 m							5500	*5640	3570	*3960	9646
	3 m			*9470	*9470	*7390	*7390	5260	*6370	3330	*4060	9921
	1.5 m			10600	*12090	6960	*8780	5020	*7150	3240	*4300	9960
	0 m	*6480	*6480	10030	*13780	6620	*9860	4820	*7820	3270	*4700	9768
	-1.5 m	*9670	*9670	9790	*14420	6430	*10460	4700	7700	3470	*5350	9330
	-3 m	*14110	*14110	9770	*14190	6380	*10470	4670	7670	3890	6310	8608
	-4.5 m	*18760	*18760	9920	*13010	6470	*9670	4790	*7170	4770	*7140	7517













- Notes : 1. The above loads are in compliance with SAE and ISO Hydraulic Excavator Lift Capacity Standards.  
 2. Rated loads do not exceed 87% of hydraulic lifting capacity or 75% of tipping load.  
 3. Rated loads marked with an asterisk (\*) are limited by hydraulic capacity rather than tipping load.

## LIFTING CAPACITY (At the arm end without bucket)

*Note: For lift capacity including bucket, simply subtract actual weight of bucket from the following values.*

### SE280NLC-3 (Shoe 600 mm, Counterweight 4800 kg)

unit : kg, mm

 Across under-carriage  Along under-carriage	Lifting hook related to ground level	3 m		4.5 m		6 m		7.5 m		Max.reach		
												Max. mm
Boom 6.2 m + Arm 2.55 m	6 m					6880	*6900	4760	*6730	4710	*6730	7537
	4.5 m			*9700	*9700	6580	*7820	4660	*6980	4040	*6850	8173
	3 m			9280	*12390	6200	*9030	4480	*7540	3700	6440	8496
	1.5 m			8710	*14240	5880	*10100	4310	7630	3580	6280	8542
	0 m			8510	*14760	5690	10500	4200	7510	3650	6470	8317
	-1.5 m	*11480	*11480	8510	*14400	5630	10440	4180	7480	3980	7090	7796
	-3 m	17100	*17940	8650	*13230	5710	*9990			4750	*8340	6911
	-4.5 m	*14320	*14320	8970	*10680					6770	*8530	5484
Boom 6.2 m + Arm 3.05 m	6 m							4820	*6130	4170	*5550	8133
	4.5 m					6660	*7230	4690	*6520	3620	*5530	8725
	3 m			9490	*11410	6260	*8500	4490	*7160	3340	*5710	9028
	1.5 m			8790	*13590	5900	*9700	4300	7630	3240	5710	9071
	0 m			8470	*14560	5660	10480	4160	7470	3290	5850	8860
	-1.5 m	*10510	*10510	8410	*14540	5560	10360	4100	7400	3540	6330	8374
	-3 m	16770	*17470	8490	*13700	5590	*10270	4160	7470	4120	7390	7558
	-4.5 m	*16120	*16120	8750	*11710	5800	*8560			5470	*7950	6283
Boom 6.2 m + Arm 4.0 m	6 m							4940	*5130	3450	*3960	9116
	4.5 m							4770	*5640	3050	*3960	9646
	3 m			*9470	*9470	6410	*7390	4540	*6370	2830	*4060	9921
	1.5 m			9030	*12090	5970	*8780	4300	*7150	2740	*4300	9960
	0 m	*6480	*6480	8480	*13780	5630	*9860	4100	7420	2760	*4700	9768
	-1.5 m	*9670	*9670	8240	*14420	5450	10250	3980	7280	2930	5300	9330
	-3 m	*14110	*14110	8220	*14190	5400	10190	3950	7250	3290	5970	8608
	-4.5 m	16540	*18760	8370	*13010	5480	*9670	4070	*7170	4060	*7140	7517













- Notes :
- The above loads are in compliance with SAE and ISO Hydraulic Excavator Lift Capacity Standards.
  - Rated loads do not exceed 87% of hydraulic lifting capacity or 75% of tipping load.
  - Rated loads marked with an asterisk (\*) are limited by hydraulic capacity rather than tipping load.

## LIFTING CAPACITY (At the arm end without bucket)

*Note: For lift capacity including bucket, simply subtract actual weight of bucket from the following values.*

### SE280NLC-3 (Shoe 600 mm, Counterweight 5400 kg)

unit : kg, mm

 Across under-carriage  Along under-carriage	Lifting hook related to ground level	3 m		4.5 m		6 m		7.5 m		Max.reach		Max. mm
												
Boom 6.2 m + Arm 2.55 m	6 m					*6900	*6900	5060	*6730	5010	*6730	7537
	4.5 m			*9700	*9700	6970	*7820	4960	*6980	4310	*6850	8173
	3 m			9860	*12390	6590	*9030	4780	*7540	3950	6770	8496
	1.5 m			9290	*14240	6270	*10100	4610	8030	3830	6620	8542
	0 m			9090	*14760	6080	*10720	4500	7900	3920	6810	8317
	-1.5 m	*11480	*11480	9090	*14400	6030	*10750	4480	7880	4260	7460	7796
	-3 m	*17940	*17940	9230	*13230	6110	*9990			5080	*8340	6911
	-4.5 m	*14320	*14320	9550	*10680					7210	*8530	5484
Boom 6.2 m + Arm 3.05 m	6 m							5120	*6130	4440	*5550	8133
	4.5 m					7050	*7230	4990	*6520	3870	*5530	8725
	3 m			10070	*11410	6650	*8500	4790	*7160	3580	*5710	9028
	1.5 m			9370	*13590	6290	*9700	4600	*7810	3470	6020	9071
	0 m			9050	*14560	6050	*10490	4460	7860	3540	6170	8860
	-1.5 m	*10510	*10510	8980	*14540	5960	*10720	4400	7790	3810	6670	8374
	-3 m	*17470	*17470	9070	*13700	5990	*10270	4460	*7790	4420	*7690	7558
	-4.5 m	*16120	*16120	9330	*11710	6190	*8560			5840	*7950	6283
Boom 6.2 m + Arm 4.0 m	6 m							*5130	*5130	3690	*3960	9116
	4.5 m							5070	*5640	3270	*3960	9646
	3 m			*9470	*9470	6800	*7390	4840	*6370	3050	*4060	9921
	1.5 m			9610	*12090	6360	*8780	4600	*7150	2950	*4300	9960
	0 m	*6480	*6480	9050	*13780	6030	*9860	4400	7820	2980	*4700	9768
	-1.5 m	*9670	*9670	8820	*14420	5840	*10460	4280	7680	3160	*5350	9330
	-3 m	*14110	*14110	8800	*14190	5790	*10470	4250	7650	3550	6300	8608
	-4.5 m	17630	*18760	8950	*13010	5880	*9670	4370	*7170	4360	*7140	7517

- Notes : 1. The above loads are in compliance with SAE and ISO Hydraulic Excavator Lift Capacity Standards.  
 2. Rated loads do not exceed 87% of hydraulic lifting capacity or 75% of tipping load.  
 3. Rated loads marked with an asterisk (\*) are limited by hydraulic capacity rather than tipping load.

## STANDARD EQUIPMENT

### Engine

Low-emission engine, satisfying EPA emission standards  
Air cleaner with indicator  
Electric engine shut-off  
Fuel filter and water separator  
Automatic fan belt tensioner

### Electronic control system

Advanced control system (ACS)  
Integrated mode selection system  
Self-diagnostic system  
Automatic idling system  
One-touch power boost  
Automatic engine warm-up  
Safety stop/start function  
Adjustable monitor  
Master switch  
Engine restart prevention circuit

Powerful halogen lights :

- Frame mounted 2
- Boom mounted 2

Alternator(50A)  
Batteries(2 × 12V/200Ah)  
Start motor(24V/7.5kW)

### Hydraulic system

Automatic sensing work mode

- Summation system
- Boom priority
- Arm priority

Boom and arm flow regeneration  
Anti-rebound valve  
Boom and arm holding valves  
Pilot-operated semi-long joysticks  
Multi-stage filtering system  
Cylinder cushions  
Cylinder contamination seal

Auxiliary hydraulic valve  
Straight travel circuit  
Automatic two speed travel motors

### Superstructure

Full height counterweight  
Access way with hand-rail  
Box tool

### Cab and interior

Hydraulic dampening cab mounts  
Adjustable operator seat and control console  
Flexible antenna  
Hydraulic safety lock lever  
Cab, all-weather sound suppressed, includes :  
- Ashtray

- Cigar lighter
- Door locks
- Floor mat
- Horn
- Hot & cool storage box
- Pull-up type front window
- Removable lower windshield
- Seat
- Seat belt
- Safety glass
- Windshield wiper with intermittent feature

### Undercarriage

Hydraulic track adjusters  
Sealed and grease-lubricated track chain  
Track guards

## ALTERNATIVE EQUIPMENT

### Undercarriage

- LC
- NLC

### Track shoes

- 600/700/800/900 mm track shoes with triple grousers
- 900 mm swamp shoe

### Digging equipment

Boom: 6.2 m  
6.2 m Heavy duty monobloc

### Digging equipment

Arm: 2.55 m / 3.05 m  
3.05 m Heavy duty / 4.0 m  
**Counterweight**  
4800 kg / 5400 kg

## OPTIONAL EQUIPMENT (Standard in certain markets)

### Engine

Air heater  
Block heater : 120V, 240V  
Fuel warmer  
Pre-cleaner

### Electronic control system

Overload warning device  
Fuel filler pump  
Rotating warning beacon  
Travel alarm

### Hydraulic system

Anti drop valve : boom, arm  
Hydraulics, combined function :  
- Hammer  
- Shears, crusher  
Hydraulics fit

### Cab and interior

Air conditioner  
Heater  
Cab guard  
Falling object guard (FOG)  
Stereo cassette radio (AM/FM)  
Vandalism kit

### Service

Spare parts  
Tool kit

*Under our policy of continuous improvement, we reserve the right to change specifications and design without prior notice. The illustrations do not necessarily show the standard version of the machine.*

# VOLVO

**Volvo Construction  
Equipment Group**

Ref. No. 21 1 435 1611 English global  
Printed in Korea 1999.03-1 KOR  
Volvo, Seoul

Courtesy of Machine.Market