

SAMSUNG

SE280 LC-2 NLC-2

CRAWLER EXCAVATOR SERIES-2



Flywheel Horsepower ;	180 ps	132 kW
Bucket Capacity ; SAE	1.25 m ³	1.64 yd ³
CECE	1.1 m ³	1.44 yd ³
Operating Weight ;	28500 kg	62830 lb

Samsung SE280LC/NLC-2 Excavator, Providing Outstanding Power and Economy.



The new SE280LC/NLC-2 Excavator from Samsung provides more power performance and durability than ever before. We've made refinements to the hydraulic system to provide more power and speed while also making fine control easier. At the same time, we've reinforced the boom, track frames and undercarriage to provide longer life in the toughest applications. Your operators also will appreciate the comfort and safety features offered in our unique hi-visibility cab. All in all, these machines offer you the best value on the market today.



MODERN THCHNOLOGY

By utilizing the latest electro-mechanical technology, Samsung can provide the optimum balance precision and power while offering the highest degree of efficiency and economy.



CA-MAX

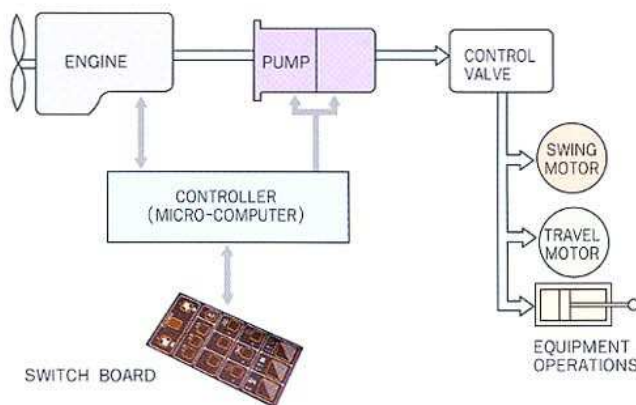

Computer-Controlled Engine Speed

While most other excavators use a mechanical throttle lever to control engine speed, Samsung utilizes a micro-computer to improve working efficiency. A simple push on the computer keypad will increase or decrease engine rpm as desired.

Push-button Auto-deceleration

Engine speed can be reduced during inactive periods, simply by pressing a button, resulting in increased fuel economy and reduced noise level.

Illuminated Switch Board

A lamp is mounted inside the switch board for easy visibility during night work.



- 3-Mode Selection System
- Self Trouble Diagnosis
- Illuminated Switch Board

Switch Board Symbols

In response to global marketing, all switch board functions are identified with internationally accepted symbols. We believe that language should not be a barrier to safety.

- ① **Self-Diagnosing Monitor**
When there is a problem in the system, a light will indicate the source of the trouble.
- ② **Engine speed :**
A full range of engine speed is available for S and L mode selections.
- ③ **Auto decel**
Engine speed is reduced to idle by pushing this switch during inactive periods.
- ④ **Mode selection**
When a mode is selected, an corresponding indicator light will come on.
- ⑤ **Travel speed**
This switch offers the operator a choice of high or low travel speed.
- ⑥ **Washer**
Sprays washer fluid on the windshield.
- ⑦ **Buzzer stop**
When alarm buzzer sounds, it may be silenced by pushing this switch.
- ⑧ **Check**
This switch checks the various instrument panel warning lights and alarm monitors.
- ⑨ **Wiper**
It offers a choice of three wiper speeds.
- ⑩ **Heater**
It offers a choice of high or low fan speed.
- ⑪ **Head/Boom light**
Headlight or combination of headlight and boom light can be selected by pressing this switch.

Mode Selection System

Samsung's three mode system makes it possible to select the speed and power to fit job conditions. This feature results in higher productivity and reduced fuel consumption.

H mode(heavy duty)

H mode provides the hydraulic pumps in 100% of engine power when working with hard ground, rock or for other difficult applications.

S mode (medium duty)

A standard mode that balances engine power and fuel costs for general excavation and loading work.

L mode (light duty)

An economical mode requiring less engine power for use in light loading, stand by or precision work.

OPERATOR COMFORT

Operator comfort is important in maintaining maximum productivity. That's why we've designed our cab with the operator in mind.

Our ultramodern design is luxurious and spacious and offers the additional benefits of conveniently placed controls and reduced noise levels.

The monitor provides both gauges and warning lights for all the important functions.

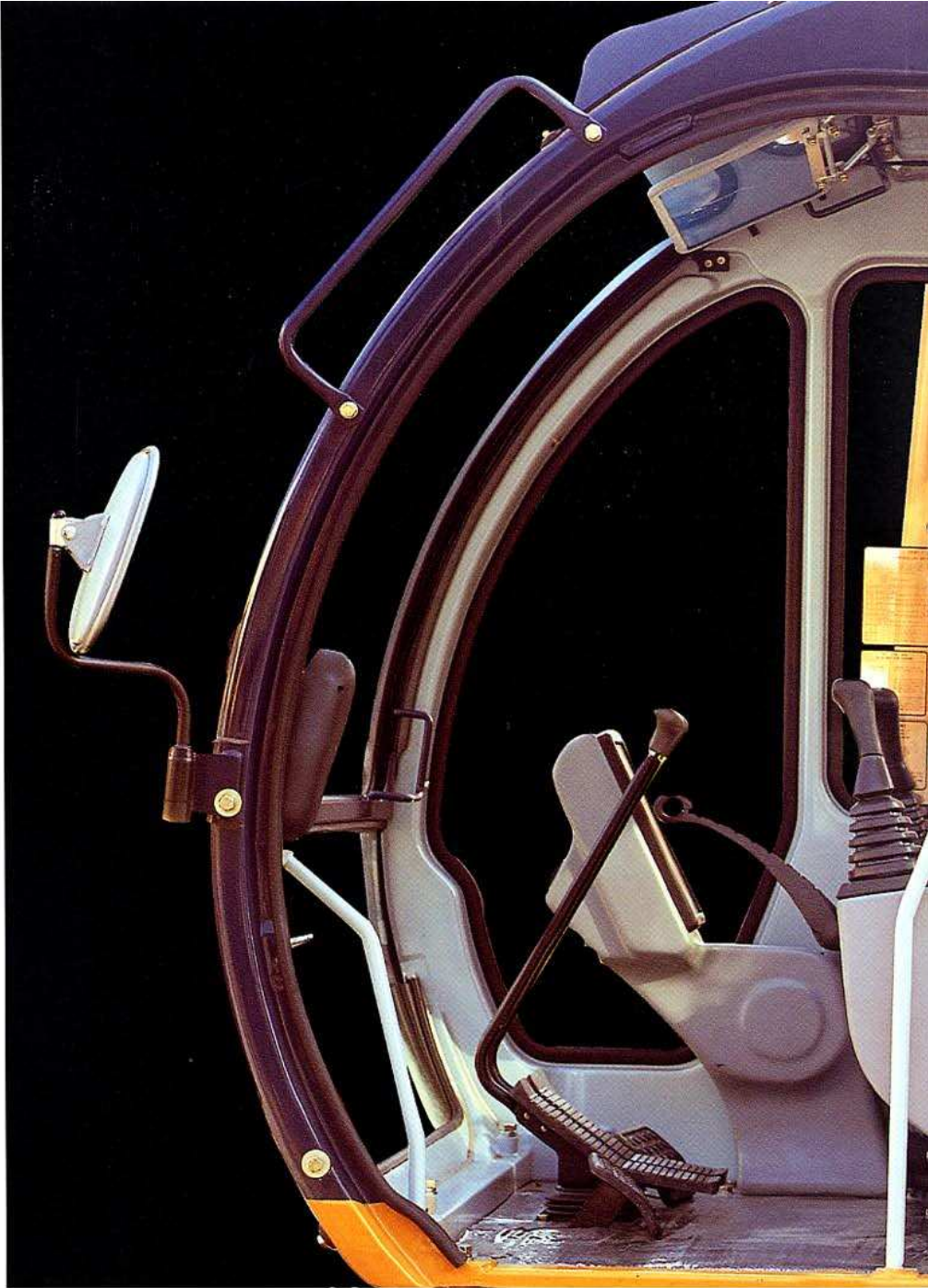

Touch Keypad Interior Climate Control

The conveniently placed, touch keypad control panel for the integrated air conditioning/heating unit, allows the operator to quickly optimize system performance. The operator can select his comfort zone utilizing the multi-vent distribution system for comfort and visibility regardless of weather conditions.

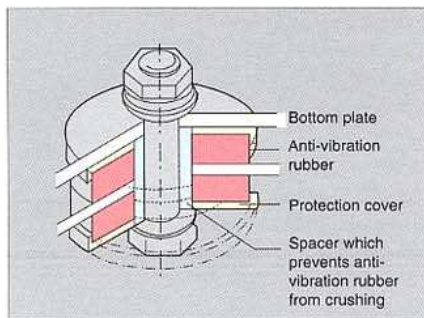

Cab Noise Control

To improve the operator's environment, the cab is insulated with sound absorbing material. Successfully lowering noise levels to 74dB(A) enhances operator performance, reducing fatigue and stress.

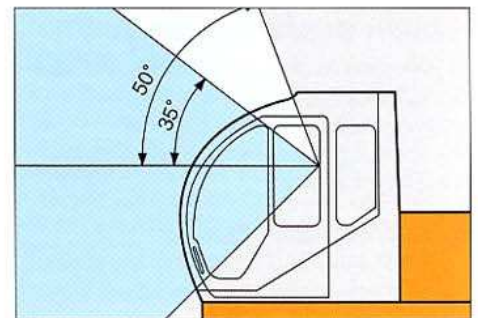

Highest visibility in the industry

The large curved front window offers a wide area of increased visibility in the upper line of sight and is easily opened by sliding upward, to the overhead storage position.



- Low-vibration, Low-noise Cab
- Highest Visibility
- Fine Control-Semi Long Lever
- Removable Bottom Window

KAB/Seating

- ① vertical tilt
- ② vertical height control
- ③ front-rear control
- ④ back of chair angle control
- ⑤ armrest angle control
- ⑥ headrest angle control
- ⑦ headrest height control
- ⑧ adjustment for operator weight

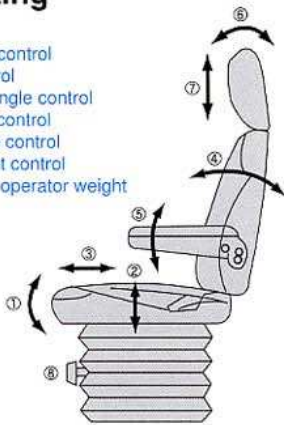

Deluxe KAB Seat

A deluxe KAB seat is installed as standard equipment, providing full adjustment for each operator's weight and size, resulting in the ultimate operator comfort.



Overload Warning Device(Option)

The overload warning device is factory adjusted to reflect over-the-side lifting capacity of the boom and arm configuration of the machine.

Manual Control of Engine Speed

In case an abnormality occurs in the work mode selection system, simple transfer to manual control can be done by reassembling the lever mounted inside the cab.

Removable Front Bottom Window

Improved low angle visibility can be achieved by quick removal of front bottom window.

Semi Long Lever

Adoption of the semi-long lever, which is longer than the previous one, enables excellent fine control and requires less effort.

Stereo/Cassette

The high quality car stereo cassette provides excellent sound reproduction.

Redesigned Duct System

The installation of a new duct system provides a balanced distribution of air flow to the interior for air conditioning/heating and to the windows when in defrost mode.

MAXIMUM PRODUCTIVITY

Samsung Hydraulic Excavators matches engine power with hydraulic output to provide the right combination of speed and power in any application.



Expanded Working Range

The reach, dig depth and dump height capabilities of Samsung excavators are among the highest in the class. You can handle more work with less maneuvering.

Smooth Simultaneous Operation

Refinements to the hydraulic system allow for smooth simultaneous operation of the travel, swing, arm, boom and bucket functions.

Working Stability

A heavier counterweight provides increased balance and stability with various work attachments such as hammers, special buckets and forestry fronts.



Outstanding Digging Performance

High breakout forces provide more than enough power to handle even the toughest job conditions with ease. Samsung hydraulic excavators can also be fitted with a wide range of buckets to increase productivity.



- Smooth Simultaneous Operation
- Excellent Bucket Response
- Optimum Machine Balance

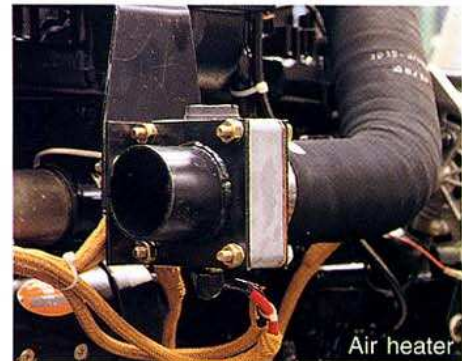
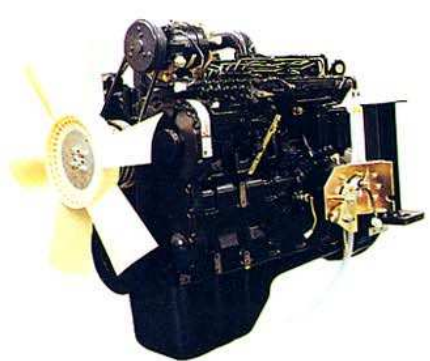

High Capacity Cummins Engine

The Cummins engine has long been acknowledged for capacity and durability throughout the world. Its excellent combustion efficiency results in an economical, powerful engine that really proves itself in severe weather conditions. Cold weather starting capacity is excellent, fuel costs are minimal and excellent parts & service support is readily available.

Improved Start-up in Cold Weather Conditions

An electric air heater and fuel warmer are provided as optional equipment. Heating the fuel prior to start-up prevents filter blockage for easier cold weather starts.

ADVANCED DESIGN CONCEPT

Samsung Hydraulic Excavators have been computer-designed to provide greater structural integrity, stability and durability which will extend the service life of major structural components.



Stronger Undercarriage Components

By increasing the hardness of the pins and bushings and improving the material composition of the links, rollers, idlers, and sprockets, we've added more usable life to our undercarriage.

Travel motor covers have also been increased in thickness for better protection of the motor and piping.

Automatic Swing Brake

The swing brake is automatically applied when the swing movement stops. This prevents drift of the upper structure during slope operations.

Two Speed Travel

This feature allows the operator to travel in low gear when working in rough terrain or when slow movement is desired, and high gear for travel between job areas.

Reinforced Frames

Both upper and lower frames have been reinforced for longer life.

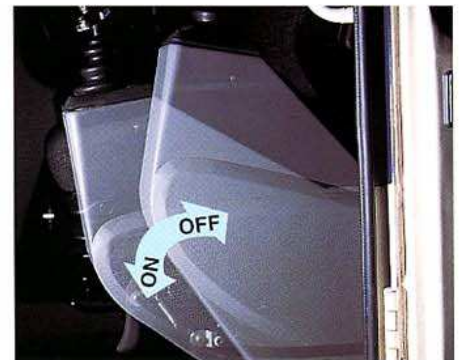

Hydraulic Safety Lock

All controls become inoperable when the left side control console is raised. This feature provides extra safety as well as increased room for the operator.



Carrier Rollers

High quality, sealed and lubricated carrier rollers help maintain track tension and reduce premature wear on the undercarriage.

Track Guard

The center-mounted track guard helps to prevent track disengagement.



Large Boom Light

Apart from the body head light, two separate large boom lights are installed to enhance the work conditions at night.

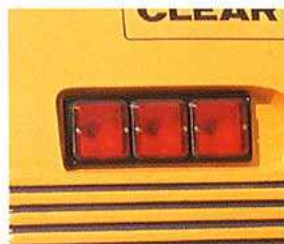

Recessed Tail Lights

Tail lights are recessed into the counterweight to protect against breakage.

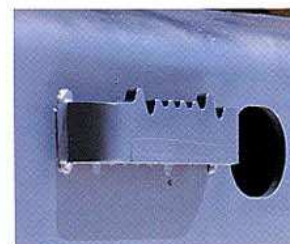

Anti-slip Step

Provides the operator with sure footing when entering or exiting the cab.

EASY MAINTENANCE

The spacious engine room and lift-up side covers make access to the engine compartment fast and easy.



Simplified Hydraulics

Samsung excavators utilize fewer hydraulic lines and hoses. As a result, maintenance is minimized and fewer parts are required.

Large Capacity Radiator

The large capacity radiator provides excellent engine cooling and protects against overheating.

Easy Access Oil Filter

The engine oil filter is conveniently located for easy access to inspect or change.



Easy Replacement of Bucket Teeth

Samsung bucket teeth are connected with a single side pin for quick and easy replacement.

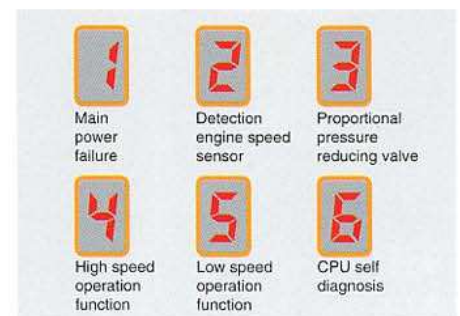

Self-Diagnosing Monitor System

This system monitors 6 vital machine functions. If trouble occurs in one of these functions, the monitor will identify it and eliminate the need for further troubleshooting procedures.

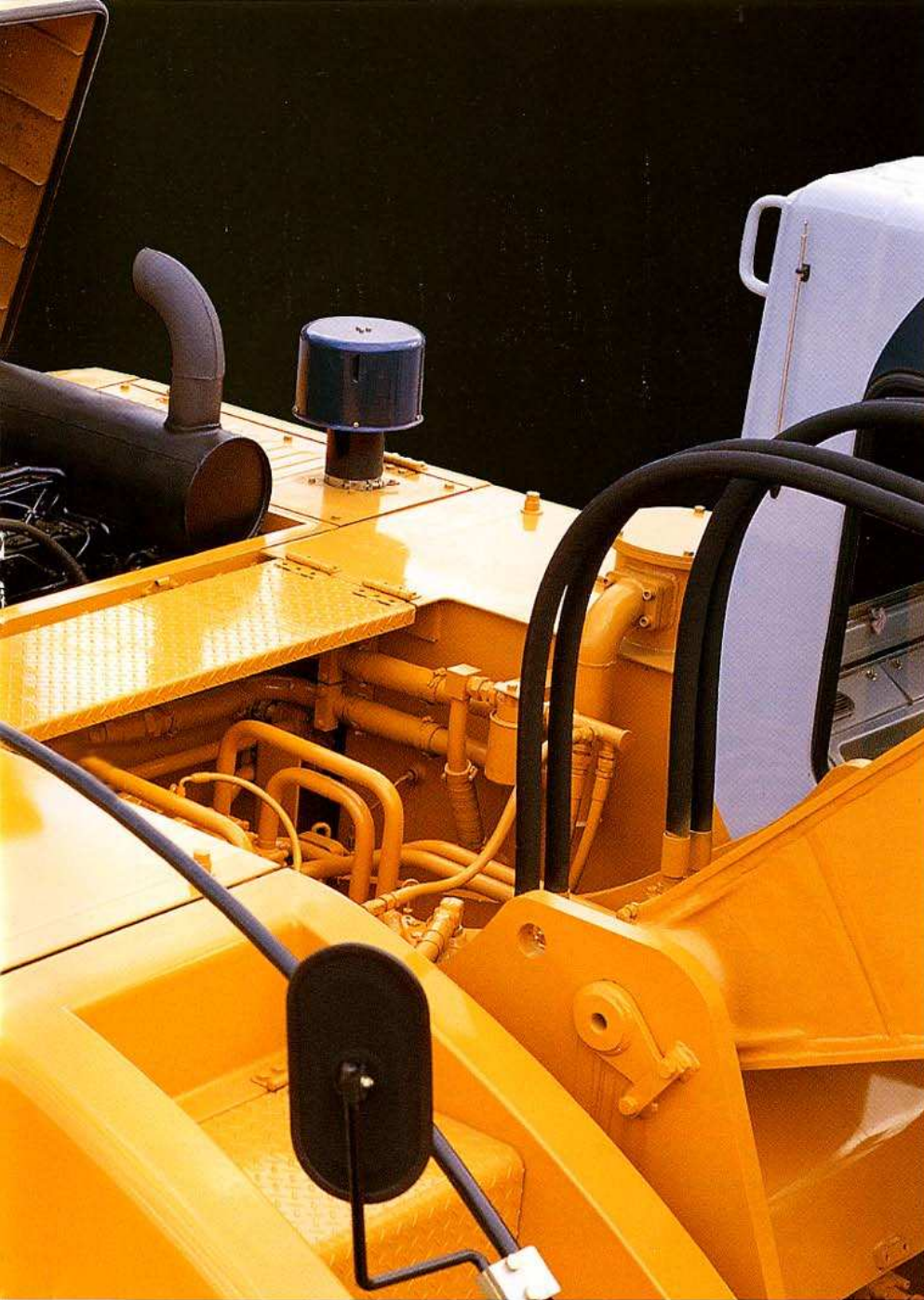

- Self Diagnosing Monitor System
- Centralized Grease Injection Points for the Swing Ring and Attachment



Engine Cooling Fan

The engine cooling fan is made of a tough plastic material to reduce noise while maintaining excellent air flow efficiency.

Engine Hood Locks

Locks are installed on the engine hood and side doors to protect against vandalism.



Cooling Water Auxiliary Tank

Enables easy check and replenishment of coolant by opening the side door.

Centralized Grease Injection Points

Easier, faster lubrication of the swing ring and attachments.

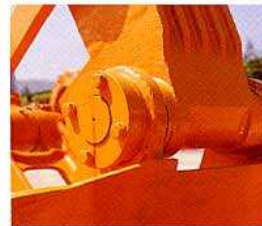

Easy Bucket Adjustment

The flange can be disassembled to adjust the bucket fit for extended life and less noise.

Auto Fuel Pump(Optional)

Allows easier fueling when desired.



Shipping Dimensions

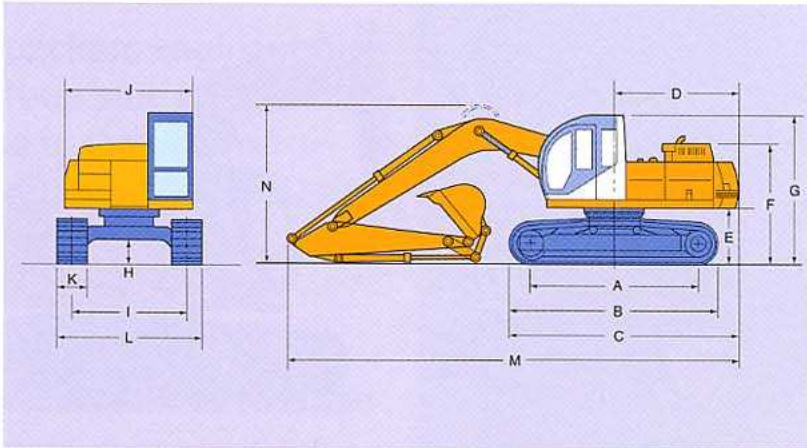

	SE280LC-2 / SE280NLC-2
A. Distance between tumblers	4,020mm (13' 2")
B. Undercarriage length	4,930mm (16' 2")
C. Length of base machine	5,430mm (17' 10")
D. Tail swing radius	2,970mm (9' 9")
E. Counterweight clearance	1,150mm (3' 9")
F. Height without cab	2,450mm (8' 0")
G. Overall height of cab	3,050mm (10' 0")
H. Min. ground clearance	500mm (1' 8")
I. Track gauge	2,590mm (8' 6")
J. Upper Frame Width	2,840mm (9' 4")
K. Track shoe width	600mm (2' 0")
L. Overall width	3,190mm (10' 6")
M. Overall length	10,540mm (34' 7")
N. Overall height of boom	3,370mm (11' 1")

Working Ranges

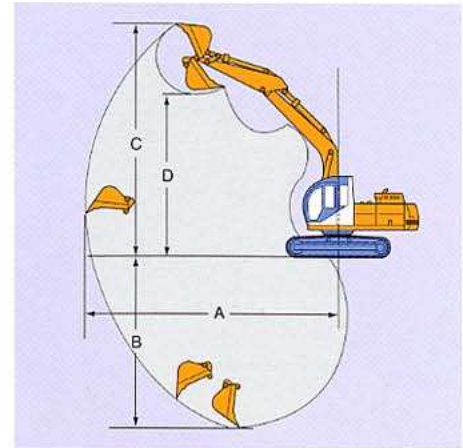

	SE280LC-2/SE280NLC-2
Boom Length	6,300mm (20' 8")
Arm Length	3,000mm (9' 10")
Max. Digging Reach (A)	10,780mm (35' 4")
Max. Digging Depth (B)	7,500mm (24' 7")
Max. Digging Depth (8' level)	7,240mm (23' 9")
Max. Digging Height (C)	10,160mm (33' 4")
Max. Dumping Height (D)	7,120mm (23' 4")

Specifications

	SE280LC-2 / SE280NLC-2
■ Operating Weight	28500kg (62830 lb)
■ Bucket Capacity	0.6 ~ 1.5m ³ (CECE) 0.85 ~ 2.22cu.yd (SAE. PCSA)

■ Engine

Model	Cummins 6CT8.3-C
Type	Water Cooled 6 Cylinder
Flywheel Horsepower	180ps/178hp/132kw at 1900rpm
Max. Torque	76kg.m (550 ft.lb) at 1500rpm
Fuel Tank Capacity	430l (114 US gallon)

■ Hydraulic

Type	2 Variable Axial Piston Pumps
System Pressure	320kg/cm ² (4552 psi)
Max. Flowrate	2 × 255 l /min (2 × 67.4 US gallon/min)

■ Performance

Swing Speed	9.7rpm
Travel Speed	2.9/4.4km/h (1.8/2.7mph)
Digging Force (Bucket/Stick)	16.6/12.6ton (36600/27780 lb)
Tractive Effort (1sp/2sp)	21.3/14.3ton (46960/31530 lb)
Ground Pressure	0.55kg/cm ² (7.82psi) at 600mm shoe 0.42kg/cm ² (5.97psi) at 800mm shoe

Lifting Capacities

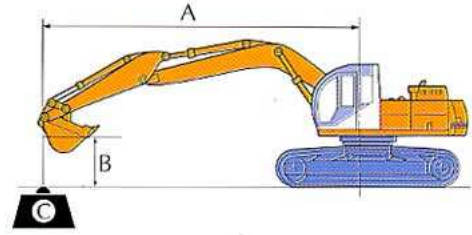

SE280LC-2 (Shoe 600mm+Bucket 1.1m³)

A: Load radius B: Load point height, kg (lb)

	B	1.5m		3.0m		4.5m		6.0m		7.5m		9.0m		max.	
		FRONT	SIDE	FRONT	SIDE	FRONT	SIDE	FRONT	SIDE	FRONT	SIDE	FRONT	SIDE	FRONT	SIDE
Boom 6.3m + Arm 3.0m	7.5m													*4045 (*8918)	*4045 (*8918)
	6.0m									*5026 (*11080)	4765 (10505)			*3876 (*8545)	*3876 (*8545)
	4.5m					*7666 (*16900)	*7666 (*16900)	*6183 (*13631)	*6183 (*13631)	*5507 (*12141)	*4647 (*10245)			*3910 (*8620)	*3367 (7423)
	3.0m					*10527 (*23208)	10227 (22546)	*7556 (*16658)	6490 (14308)	*6226 (*13726)	4459 (9830)	*4867 (*10730)	3152 (6949)	*4094 (*9026)	3083 (6797)
	1.5m					*12824 (*28272)	9486 (20913)	*8855 (*19522)	6118 (13488)	*6970 (*15366)	4269 (9411)	5161 (11378)	3077 (6784)	*4469 (*9852)	2991 (6594)
	0m					*13921 (*30690)	9173 (20223)	*9768 (*21534)	5878 (12959)	6900 (15212)	4129 (9103)			*5067 (*11171)	3076 (6781)
	-1.5m			*11353 (*25029)	*11353 (*25029)	*14106 (*31098)	9130 (20128)	9856 (21728)	5786 (12756)	6838 (15075)	4072 (8977)			5681 (12524)	3381 (7454)
	-3.0m	*13334 (*29396)	*13334 (*29396)	*17702 (*39026)	*17702 (*39026)	*13539 (*29848)	9257 (20408)	9910 (21847)	5833 (12859)	6909 (15232)	4136 (9118)			6758 (14899)	4050 (8929)
	-4.5m			*17000 (*37478)	*17000 (*37478)	*11931 (*26303)	9558 (21071)	*8563 (*18878)	6059 (13358)					*7818 (*17235)	5587 (12317)
	Boom 6.3m + Arm 2.5m	7.5m							*5248 (*11570)	*5248 (*11570)					*5448 (*12011)
6.0m								*5646 (*12447)	*5646 (*12447)	*5524 (*12178)	4603 (10148)			*5556 (*12249)	4428 (9762)
4.5m						*8535 (*18816)	*8535 (*18816)	*6685 (*14738)	*6685 (*14738)	*5882 (*12967)	4522 (9969)			*5761 (*12701)	3731 (8225)
3.0m								*8002 (*17641)	6329 (13953)	*6531 (*14398)	4355 (9601)			5637 (12427)	3386 (7465)
1.5m								*9186 (*20251)	5995 (13217)	6968 (15362)	4188 (9233)			5507 (12141)	3279 (7229)
0m						*14059 (*30994)	9099 (20060)	9877 (21775)	5803 (12793)	6845 (15090)	4078 (8990)			5707 (12582)	3389 (7471)
-1.5m				*11819 (*26056)	*11819 (*26056)	*13910 (*30666)	9120 (20106)	9826 (21662)	5759 (12696)	6824 (15044)	4059 (8948)			6342 (13982)	3776 (8325)
-3.0m				*18320 (*40388)	*18320 (*40388)	*13054 (*28779)	9306 (20516)	*9624 (*21217)	5857 (12912)					7794 (17183)	4660 (10273)
-4.5m				*15265 (*33653)	*15265 (*33653)	*10931 (*24098)	9685 (21351)							*8448 (*18624)	6941 (15302)

SE280NLC-2 (Shoe 600mm+Bucket 1.1m³)

kg (lb)

	B	1.5m		3.0m		4.5m		6.0m		7.5m		9.0m		max.	
		FRONT	SIDE	FRONT	SIDE	FRONT	SIDE	FRONT	SIDE	FRONT	SIDE	FRONT	SIDE	FRONT	SIDE
Boom 6.3m + Arm 3.0m	7.5m													*4045 (*8918)	*4045 (*8918)
	6.0m									*5026 (*11080)	4473 (9861)			*3876 (*8545)	3675 (8102)
	4.5m					*7666 (*16900)	*7666 (*16900)	*6183 (*13631)	*6183 (*13631)	*5507 (*12141)	4357 (9605)			*3910 (*8620)	3144 (6931)
	3.0m					*10527 (*23208)	9491 (20924)	*7556 (*16658)	6068 (13377)	*6226 (*13726)	4172 (9198)	*4867 (*10730)	2938 (6477)	*4094 (*9026)	2872 (6332)
	1.5m					*12824 (*28272)	8774 (19343)	*8855 (*19522)	5704 (12575)	*6970 (*15366)	3985 (8785)	5333 (11757)	2863 (6312)	*4459 (*9830)	2782 (6133)
	0m					*13921 (*30690)	8470 (18673)	*9768 (*21534)	5469 (12057)	7120 (15697)	3847 (8481)			*5067 (*11171)	2861 (6307)
	-1.5m			*11353 (*25029)	*11353 (*25029)	*14106 (*31098)	8429 (18582)	10157 (22392)	5379 (11858)	7057 (15558)	3792 (8360)			5868 (12937)	3146 (6936)
	-3.0m	*13334 (*29396)	*13334 (*29396)	*17702 (*39026)	17419 (38402)	*13539 (*29848)	8552 (18854)	*9924 (*21878)	5425 (11960)	7128 (15714)	3855 (8499)			6973 (15373)	3774 (8320)
	-4.5m			*17000 (*37478)	*17000 (*37478)	*11931 (*26303)	8844 (19497)	*8563 (*18878)	5646 (12447)					*7818 (*17235)	5212 (11490)
	Boom 6.3m + Arm 2.5m	7.5m							*5579 (*12299)	*5579 (*12299)					*5761 (*12701)
6.0m								*5879 (*12961)	*5879 (*12961)	*5783 (*12749)	4576 (10088)			*5817 (*12824)	4411 (9724)
4.5m						*8515 (*18772)	*8515 (*18772)	*6783 (*14954)	6395 (14098)	*6071 (*13384)	4424 (9753)			*5985 (*13194)	3708 (8175)
3.0m								*7969 (*17568)	5872 (12945)	*6645 (*14650)	4183 (9222)			6031 (13296)	3346 (7377)
1.5m								*9065 (*19985)	5451 (12017)	7250 (15983)	3962 (8735)			5867 (12934)	3213 (7083)
0m						*13650 (*30093)	7896 (17407)	*9778 (*21556)	5225 (11519)	7098 (15648)	3828 (8439)			6041 (13318)	3284 (7240)
-1.5m				*11058 (*24378)	*11058 (*24378)	*13531 (*29830)	7962 (17553)	9936 (21905)	5191 (11444)	7096 (15644)	3826 (8435)			6656 (14674)	3612 (7963)
-3.0m				*17661 (*38935)	16657 (36722)	*12720 (*28042)	8205 (18089)	*9530 (*21010)	5345 (11784)					*7910 (*17438)	4395 (9689)
-4.5m				*14700 (*32407)	*14700 (*32407)	*10713 (*23618)	8706 (19193)							*8423 (*18569)	6435 (14187)

Note: 1. Ratings are based on SAE J1097, ISO10567.

2. Indicated loads do not exceed 75% of tipping, machine situated on firm level, uniform supporting surface or 87% of full hydraulic capacity.

3. Ratings marked " * " are limited by hydraulic capacity.

*Under our policy of continuous improvement, we reserve the right to change specifications and design without prior notice.
The illustrations do not necessarily show the standard version of the machine.*

VOLVO

**Volvo Construction
Equipment Group**

Ref. No. 21 1 435 1210
Printed in Korea 98.08-1
Volvo, Seoul

English
KOR