

可靠承载重托

Reliability in Action

产品主要性能及零部件参数·标准配置 Main performance, parts parameters and standard configuration

项目 Item	参数 Parameter
工作重量 Working weight	15400kg
整机外形尺寸 Overall dimensions	8814*2636*3400mm
发动机型号 Engine type	SC8D190G2B1
额定功率 Rated power	140kW
额定转速 Rated revolution	2300rpm
前进速度 Forward Speed	0-5.2Km/h, 0-7.9Km/h, 0-11.8Km/h, 0-17.9Km/h, 0-25Km/h, 0-38.1Km/h
后退速度 Backward Speed	0-5.2Km/h, 0-11.8Km/h, 0-25Km/h
牵引力 Traction	80.8kN
最大爬坡能力 Max. grade ability	24%
工作系统压力 Working system pressure	16MPa
前轮最大倾斜角 Max. inclination angle of the front wheel	±17°
平衡箱最大摆动角 Max. swinging angle of the balance box	±15°
前桥最大摆动角 Max. swinging angle of the front axle	±15°
铰接转向角 Steering angle of the articulated frame	±27°
最小转弯半径 Min. turning radius	7.5m
铲刀(长*弦高) Blade (Length and chord height)	3965*610mm
铲刀回旋角度 Blade rotation angle	360°
铲刀最大斜倾角 Max. inclination angle of the blade	90°
铲刀最大入地深度 Max. digging depth of the blade	500mm
轮胎规格 Tire type	17.5-25-12PR
轮胎气压 Tire pressure	0.23MPa
燃油容量 Fuel tank capacity	220L
液压油容量 Hydraulic oil tank capacity	90L

以上参数如有修改恕不通知, 文中插图并不一定是该机型的标准款。
Notice would not be given in case of any parameter change; photos herein may not be the standard type of the machine.



LGG8180
平地机
Grader

山东临工工程机械有限公司
Shandong Lingong Construction Machinery Co.,Ltd.

地址: 山东省临沂经济技术开发区临工工业园 Add: Lingong Industry Park, Economic Development Zone, Linyi, Shandong, P.R.C.
 电话: 0086-539-8785796 (国内) Tel: 0086-539-8785796 (for domestic)
 0086-531-66590966 (出口) 0086-531-66590966 (for export)
 传真: 0086-539-8785600-5050 (国内) Fax: 0086-539-8785600-5050 (for domestic)
 0086-531-66590959 (出口) 0086-531-66590959 (for export)
 客户服务: 0086-539-8785800 Customer Service: 0086-539-8785800



Courtesy of Machine.Market

LGG8180

平地机
Grader

LGG8180平地机是临工全新研发的产品。该机性能优异，造型时尚，在驱动性能、操纵性能、可靠性、维护保养和维修性能等方面都处于行业领先水平。主要用于公路、机场、农田等大面积的地面平整和开挖路基；转移土壤、碎石混合料；开边沟、刮边坡；路面平整；除雪清道等。是国防工程、矿山建设、城乡道路等建筑施工和水利建设、农田改良等必须的工程机械。

As a latest product developed by SDLG, LGG 8180 grader features preeminent performance, fashionable appearance, and advanced driving performance, operating performance, reliability and care & maintenance performance in the industry. It is mainly employed in the land leveling and roadway excavation of large areas like roads, airports, farmlands etc.; transferring of soils and crushed stones; ditching and slope scraping; pavement leveling; snow removing etc, is an indispensable engineering machinery for national defense engineering, mine construction, road construction, water conservancy project construction, farmland improvement etc.



LGG8180 平地机 · 标准配置 LGG8180 Grader -Standard Configuration

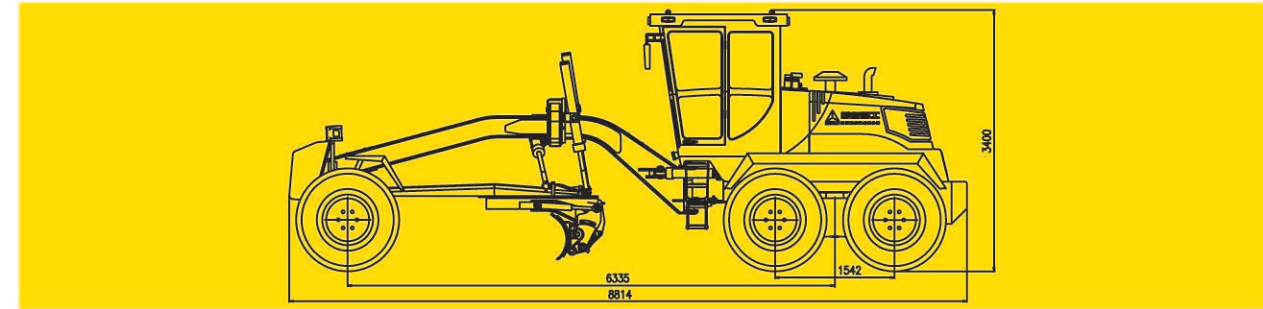

- 对整机进行创新性设计，整机前后协调统一，过渡自然，美观大方，让人耳目一新。
- 动力系统匹配合理、性能可靠；电液控制换挡箱，操纵轻便、灵活。
- 液压系统采用SEMPERIT管接头、密封件，配置快速故障检测点。
- 采用湿式制动系统，轻便、可靠。
- 驾驶室噪音低，操作舒适性好，视野清晰，配置冷暖空调，并可选配防滚翻驾驶室。
- 选用免维护大功率卷绕式环保蓄电池，具有重量轻、体积小、低温启动性好等优点。
- 可选装前推土板、后松土器，满足不同工况需求。
- Overall innovative design, offering a coordinated and uniform connection, and a natural transition of the front and rear parts; bringing a pleasant and fresh new looks to the machine.
- A power system with rational matching and reliable performance; a electro-hydraulic controlled shift box with easy and flexible operation.
- A hydraulic system adopting SEMPERIT pipe connectors and sealing elements, and fast fault detection points.
- The wet brake system which is light and reliable.
- A cab with lows voice, comfortable operation, clear and wide view, and air conditioner. The anti-roll cab is available for selection.
- The maintenance free, high power, green wound storage battery with light weight, compact size and good low temperature startup performance.
- The front bulldozing plate and rear ripper are available for installation to meet the requirements of various working conditions.

发动机 Engine

配置二阶段上柴发动机，动力强劲、可靠、高效。

The secondary-stage diesel engine from Shanghai Diesel Engine Co., Ltd. which is powerful, reliable and efficient.



变速操纵系统 Shift Control System

杭齿电液控制动力换挡箱，操纵轻便、灵活。

The electro-hydraulic controlled power shift box from Hangzhou Advance Gearbox Group Co., Ltd. which is easy and flexible in operation.

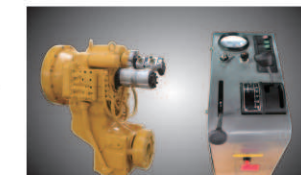

驱动桥 Drive axle

行业专用驱动桥及平衡箱，便于维护；加强型平衡箱使整机在任何恶劣工况都能获得强大附着力。

Dedicated drive axle and balance box offering easy maintenance; enhanced balance box providing a powerful adhesive force to the machine in any harsh working conditions.



液压系统 Hydraulic System

配置SEMPERIT管接头，双密封结构，无泄漏；故障快速检测点，便于维护。

It adopts SEMPERIT pipe connectors and double sealing structure free of leakage. The arrangement of fast fault detection points makes maintenance easy.



机架 Frame

中央铰接机架和偏转式转向轮，可实现整机蟹行。

It adopts the central articulated frame and front wheel with deflection-type steering which supports the crab travel of the machine.



作业装置 Operating Apparatus

滚盘式作业装置，免维护。

It adopts maintenance free disc-type operating apparatus.



机罩 Engine hood

全新设计，美观牢固。

Brand new design, with good looks and firm structure.

