

Stellar® Adjustable Sliding Jib Hooklift Hoists

SLIDER20-S



TECHNICAL SPECIFICATION GUIDE

The Stellar® Slider20-S hooklift loader is a container handling system mounted on a truck chassis that is capable of loading, unloading and dumping various containers with lengths ranging from 10' to 14' with the use of a sliding hexagonal jib.

The rectangular jib reduces flex and provides greater structural integrity. The Stellar Slider20-S has up to 20,000 pound capacity with a maximum dump angle of 60°.

This class of hooklift is known for its versatile design, ease of operation and popularity in the waste industry. All models of the Stellar Slider feature greaseable bushings, the Stellar patented dump/load interlock system, and an efficient high flow/high pressure hydraulic system with standard power beyond port to provide hydraulics to other accessories. Rugged rear body tie-downs ensure body stability when in transit). Stellar Slider hooklifts provide a full-length dump frame and rollers positioned throughout the loader, instead of saddles with wear pads. All Stellar hooklifts operate using in-cab controls. This allows for precise metering of the manual hydraulic valve while offering a clear and safe view of the operation through the rear window.



Our People. Our Products.

STELLAR® SLIDER ADJUSTABLE JIB HOOKLIFT HOIST

- Will accommodate bodies from 10-feet up to 14-feet long and still retain the maximum rated dump angle on a 40-inch high frame truck. Longer bodies may be accommodated with reduced dumping capabilities.
- Transmission-mounted PTO and hydraulic pump required to power the hooklift.
- Standard in-cab manual controls which allow for precise metering of the manual hydraulic valve.
- Twenty-five (25) gallon frame-mounted oil tank.
- Operating pressure is 4,500 psi.
- Hydraulic flow required is 24-gallons per minute.
- Valve bank equipped with power beyond port.
- Patented dump/load interface as featured on most Stellar Hooklifts.
- Hydraulic counterbalance valves to prevent cylinder collapse in case of hose failure.
- Inside or outside bolt-on slide through rear body tie-down latches.
- Plunger valve to prevent front jib movement when the dump frame is raised.
- Permanently lubricated and greaseable bushings used throughout.
- Grease zerks at all pin points to allow purging of contaminants.
- Carbon steel and zinc plated or type 17-4 stainless steel pins used throughout.
- All weldments painted with two-part polyurethane enamel.

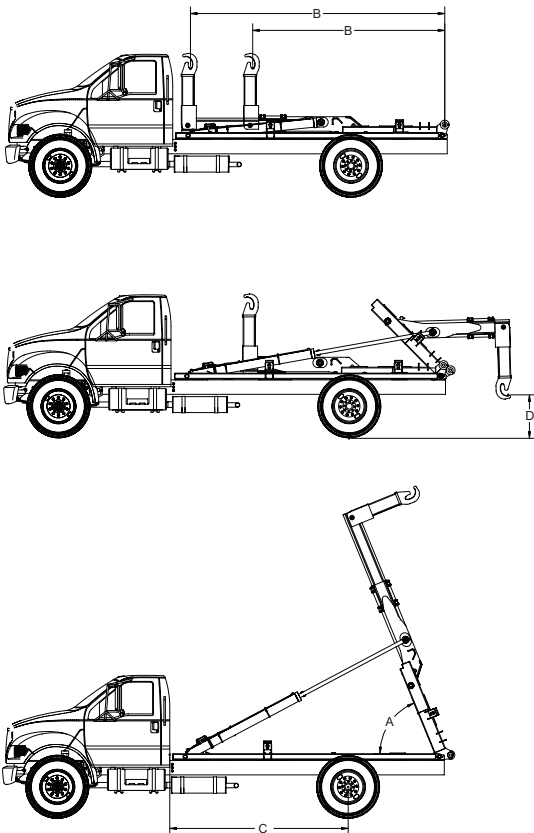

Item Description	Slider20-S
Dump/Lift Capacity	20,000 lbs (9,071 kg)
A. Dump Angle	60°
B. Effective Length	112" - 142" (2.85 - 3.6 m)
C. Cab to Axle	108" - 120" (2.74 - 3.05 m)
D. Lowest Hook Height	27.63" to 9.25" (7 - 2.4 m)
Shipping Weight	2,910 lbs (1,320 kg)
Rec. Container Lengths	10' - 14' (3.05 - 4.26 m)
Hook Height	35.63" or 54" (9.05 or 1.37 m)
Min. Truck GVWR	22,000 lbs (9,979 kg)

*When using a tarping system - add 12" to C.A. or C.T.

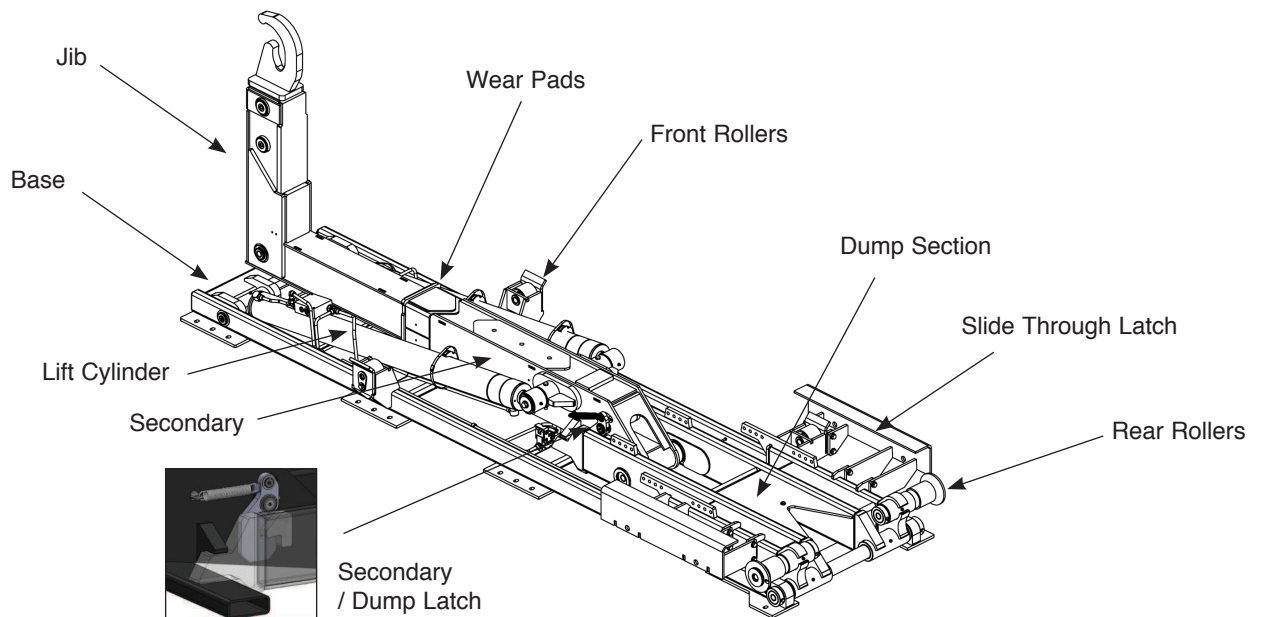

Base Section

The base section of a Stellar Slider may also be called a sub-frame. All Stellar Slider hooklifts are tied together in one common framework. This base section not only adds strength to the hooklift, but it places less stress concentration on the truck chassis than hooklifts without a common base. The base section provides for simple installation on most truck chassis.

Latches

Inside and or outside bolt-on latches for ease of installation and replacement.

Jib/Secondary

The sliding jib allows for a wider range of container lengths and a means to control the truck's weight distribution while remaining in the latches. The jib and secondary booms are rectangular shaped for structural integrity.

Wear Pads

Easily replaceable wear pads for the jib/secondary boom assemblies that can be changed in minutes. Not necessary to disassemble hooklift to replace wear pads. The wear pads ensure long life for the jib/secondary assemblies.

Dump Section

Dumping is accomplished through rear pivot point. Jib and dump sections must lock, by means of mechanical latch, together to support the full length of container/body when in the dump mode.

Skid Rollers

These three sets of rollers allows skid to roll freely forward and backwards while operating the jib. Prevent long sills from wearing prematurely, not dragging steel on steel. Also eliminates the need to replace wear pads on base frame.

Bushings and Zerks

Bushings and grease zerks at all pivot points.

Counterbalance Valves

Counterbalance valves are used on all cylinders, protecting both extend and retract functions in case of a hydraulic hose failure.

Pins

Carbon-steel and zinc-plated or type 17-4 stainless steel to prevent corrosion.



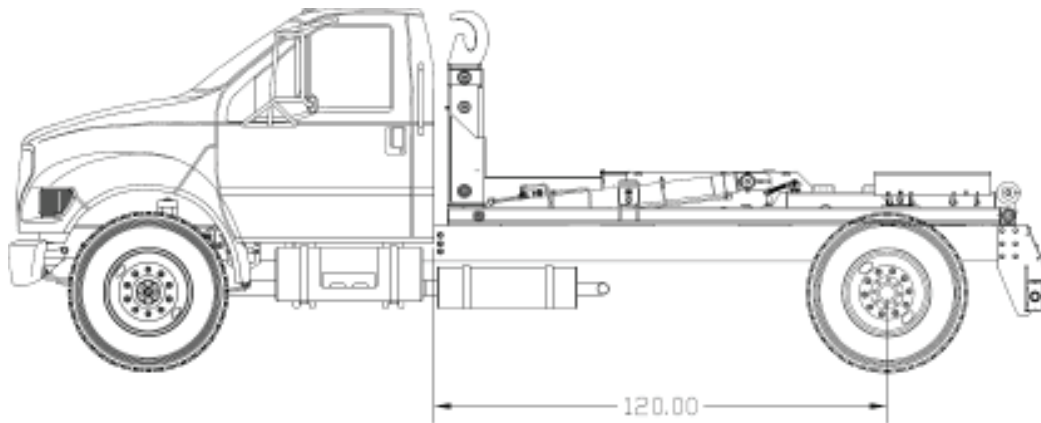
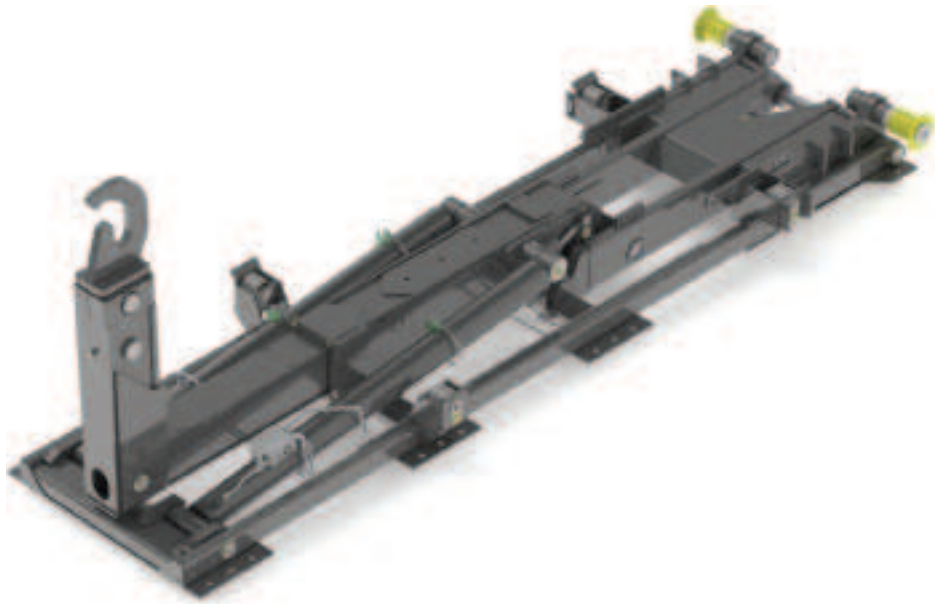

*Photos are for articulation reference and may not be the exact model on this specification sheet.

Your local dealer:



190 State Street
P.O. Box 169
Garner, IA 50438
(641) 923-3741 • (800) 321-3741
www.stellarindustries.com

Government specifications available.

* All specifications are subject to change without notification.

For the most up to date version of this brochure, please visit www.stellarindustries.com.

An Employee Owned Company.
Copyright © 2021 Stellar Industries, Inc.

STL000088 6/21

Courtesy of MachineMarket