

Tiger[®] 690

Wheel Dozer Conversion

for Caterpillar[®] 992C and 992D Wheel Loaders



Manufactured and distributed by



Tiger 690 Wheel Dozer Conversion

The Tiger 690 Story

First released in Western Australia in 1981, the Tiger 690 introduced a new dimension to the wheel dozer concept. With the production capabilities of the largest track-type machine available at the time, combined with the mobility and versatility of the smaller wheel dozers, the Tiger 690 quickly set new standards throughout industry.

Tiger's policy of continual product improvement over the years, such as the incorporation of the Cat® 773B lock-up torque converter with advanced electronic control, and single lever blade control further enhanced the machines reputation.

This experience and reputation can be used to convert your

Caterpillar 992 Wheel Loader

into a

Tiger 690 Wheel Dozer

Using the proven Cat D10N hydraulic system including twin blade lift cylinders and direct coupled controls, combined with all the proven features of the former models, a Conversion Kit gives you the ability to dramatically increase the service life of your Cat 992 Loaders no longer required, or considered suitable for loading operations.





Conversion Kit – Cat 992 to Tiger 690

Features

- 1 New Rugged Front Frame, designed for Wheel Dozer Applications, including:
 - Solid One Piece Push Beam, 8000kg (17640lb)
 - Articulation Hitch Plates (to Caterpillar specifications)
 - Front Axle Supports (to Caterpillar specifications)
 - Box Section Construction
 - Heavy Duty Mud Guards.
- 2 Heavy Duty Push Arms with Caterpillar Mountings
- 3 Dual Caterpillar Blade Lift Cylinders
- 4 Twin Caterpillar combined Tilt and Tip Hydraulic Cylinders
- 5 Caterpillar D10N Hydraulic System - with D10N Blade Control Lever
- 6 Supplied with Caterpillar 773B Off Highway Truck Torque Converter with Electronic Lock-up System
- 7 Choice of Dozer Blades: Semi "U" or Coal. Fitted with Caterpillar Standard Hardware and G.E.T
- 8 Comprehensive instructions for easy on-site assembly.



This kit is available for 992C and D Series Loaders.

Please specify Serial Number when requesting a Quotation.

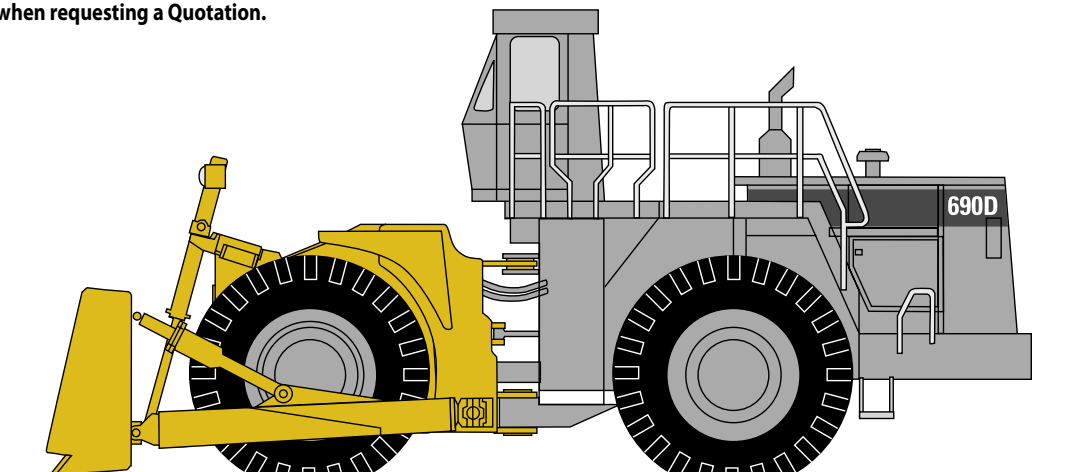

Blades

Semi - U - Blade
Capacity 24.4 yd³ (18.6 m³)
Back View

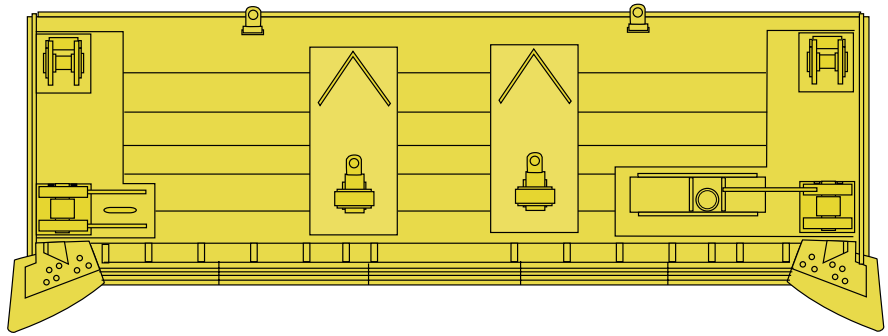

- Caterpillar mounting points and trunnions
- Caterpillar lift cylinder brackets
- Heavy duty design for rock application
- Designed with excellent dozing and rolling characteristics
- High strength pressed rib construction
- Caterpillar D10N bolt on cutting edges and bottom wear plates
- Re-buildable for long blade life

Bottom View

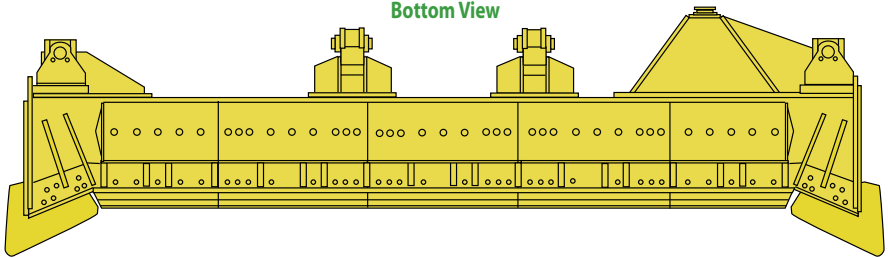

Coal - U - Blade
Capacity 50 yd³ (38.2 m³)
Top View

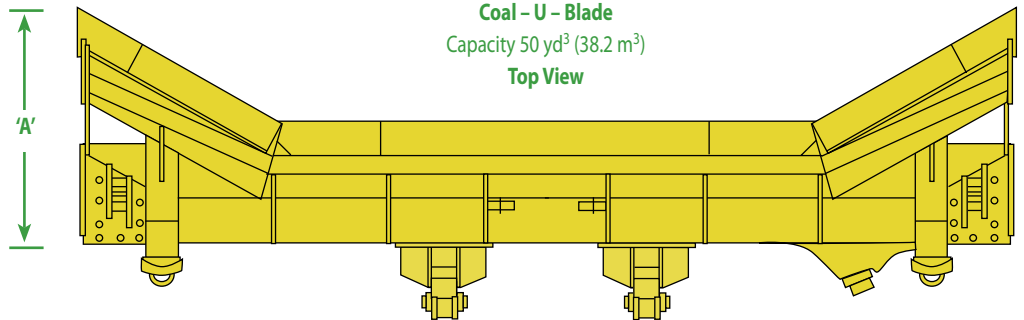

end view 'A'

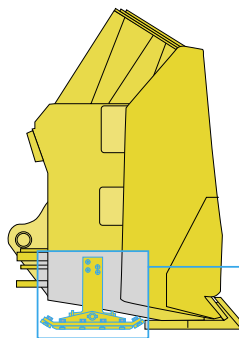

shoe detail 'A'

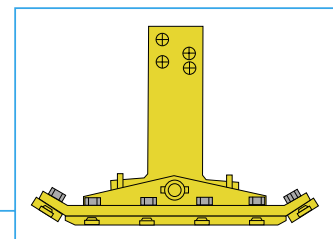

BLADE OPTIONS

BLADE TYPE	CAPACITY	OVERALL WIDTH	HEIGHT	DIGGING DEPTH	GROUND CLEARANCE	MAXIMUM TILT	WEIGHT	TOTAL OPERATING WEIGHT
SEMI-U	24.4yd ³	244"	74"	33.5"	60"	42"	20 900 lbs	197 900 lbs
	18.6m ³	6200mm	1880mm	850mm	1524mm	1066mm	9500 kg	89 955 kg
COAL	50.0yd ³	262"	92"	33.5"	60"	45"	17 600 lbs	194 600 lbs
	38.2m ³	6655mm	2337mm	850mm	1524mm	1150mm	8000 kg	88 455 kg

SEMI-U BLADE This unit combines the characteristics of the S and U - blades into one package. It has increased capacity by the addition of SHORT WINGS which include ONLY THE DOZER END BITS.

Conversion Kits

A kit represents a very economical method of turning your surplus or non-productive Cat 992 wheel loaders into cost effective, highly productive, economical Tiger 690 Wheel Dozers.

The kit basically consists of a new front frame, new hydraulic system, new lock-up torque converter and new dozer blade of your choice.

The front axle and drive line are removed from your existing 992 and put aside for use in the new dozer. The entire front tower, including the loader frame and bucket, are removed from your 992 and put aside, as are both hydraulic pumps and the torque converter. All these items can be sold, used to repair other machines on site, refurbished and put into your own parts exchange system etc. Whatever they are used for, this value should be taken into account when costing a conversion.

Fitting the new front frame and the rest of the components requires around 250 hours of labour, not allowing for any refurbishing of the Cat 992 portion.



Dimensions

(Approx, with standard tyres)

Tread width.....	10' 10"	(3202 mm)
Maximum width over tyres.....	14' 9"	(4495 mm)
Ground clearance.....	21"	(544 mm)
Width over push beam (trunnions removed).....	16' 1"	(4894 mm)

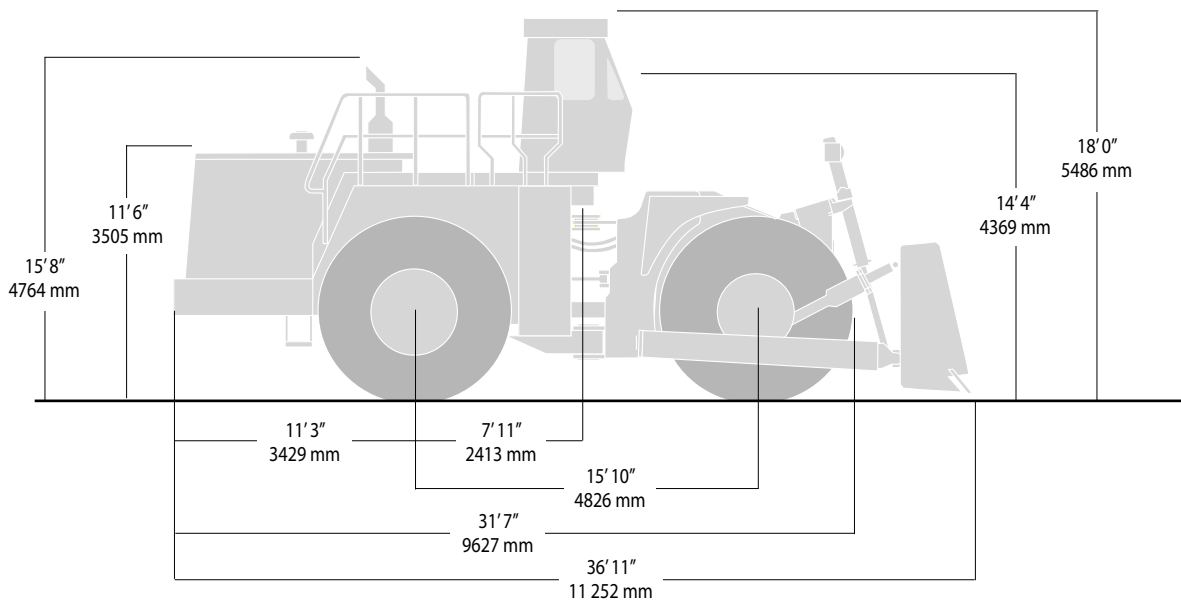

Note
Materials and Specifications are subject to change without notice.

Caterpillar, Cat and STIC are registered trademarks of Caterpillar Inc.



Authorised manufacturers and distributors of Tiger wheel dozers and forestry equipment

DAAK Engineering Pty Ltd

Perth

14 Clapham Street, Beckenham, Western Australia 6107

Telephone: (08) 9258 9333 Fax: (08) 9258 9111

Email: sales@daak.com.au Web: www.daak.com.au

Adelaide

Telephone: (08) 8342 9333

Fax: (08) 8342 9011

SMART SOLUTIONS THAT MAKE A DIFFERENCE