

WERKLUST



- * **FULL HYDROSTATIC DRIVE**
- new dimension design.
- * **LOAD SENSING**
- more reliable and extra working capacity.
- * **FUEL SAVING 25%**
- or more working capacity,
dependent on operating and job conditions.
- * **SOUND LEVEL 78 dBA**
- effected by optimum isolation and cab mounting.
- * **SEALED PIVOT POINTS**
- keeping the dirt out and the grease in.

WHELLOADER

WG 16

**1,2-1,5 m³
(1.6-2 YD³)**





ENGINE

Make	DEUTZ DIESEL
Type	F4L 912
Horsepower	54,5 kW (74 hp)
Number of revolutions	2500 RPM
Max. torque/RPM	230 Nm/1600
Cooling	air
Starting motor/voltage	4 kW (5,3 hp)/24 V
Battery voltage/capacity	2 x 12 V/120 Ah



TRANSMISSION

Type	Hydrostatic	
Automatic drive, mechanically-hydraulically operated, speed controlled.		
Number of gear ratios forward	2	
	reverse 2	
Travel speeds	1st	2nd
forward	0-11 km/h	0-31,2 km/h (0-19.3 M/h)
reverse	0-11 km/h	0-31,2 km/h (0-19.3 M/h)



AXLES

All-wheel drive with planetary reduction in each wheelhub. With differential lock on the front axle.
Axle reduction 1 : 20,4



BRAKES

Two wheel air- over hydraulic self-adjusting disc brakes.
Mechanical parking brake mounted on the gear box.



HYDRAULIC SYSTEM (Load sensing)

Tank-capacity 95 litres (21 gallon), with gauges and filter with magnets.
Pump capacity 0-90 l/min (0-19.8 gallon)
Working pressure 210 bar. (2987 p.s.i.)
Lifting cylinders, bore and stroke 2 x 100 x 565 mm.
Tilting cylinders, bore and stroke 2 x 80 x 870 mm.
Lifting time 7 sec.
Lowering time 3 sec.
Dumping time 2 sec.



STEERING (Load sensing)

Steering angle, both directions 40°. Turning radius 4890 mm (16' 1").
Steering cylinder, bore and stroke 2 x 63 x 375 mm.



TYRES

Radial tires 15,5 x 25 EM



CAPACITIES

Fuel tank	110 litres (24.2 gallons)
Hydraulic tank	95 litres (21 gallons)
Crankcase	11 litres (2.42 gallons)
Gearbox	2,5 litres (.55 gallons)

STANDARD EQUIPMENT:

ROPS/FOPS cap, outside mirrors, work lights, window washer, fenders, tool box. connections for pressure readings, dashboard with complete instruments and warning displays, cigar lighter.

OPTIONAL EQUIPMENT:

Air conditioner. Rapid exchange system.
Backup audible alarm. Extra rear window washer. Warning light.
Automatic central lubrication system.

RAPID EXCHANGE SYSTEM

Versatility of 'WERKLUST' Wheel-loaders is increased by using the various 'WERKLUST' buckets and other implements in conjunction with the 'WERKLUST' rapid exchange system, such as: general purpose bucket, skeleton bucket with detachable inner and side plates, silo bucket, rock bucket, brick bucket, light or heavy material buckets, tube- or tree clamps, mounting shield with lifting forks, hoist boom with hook.

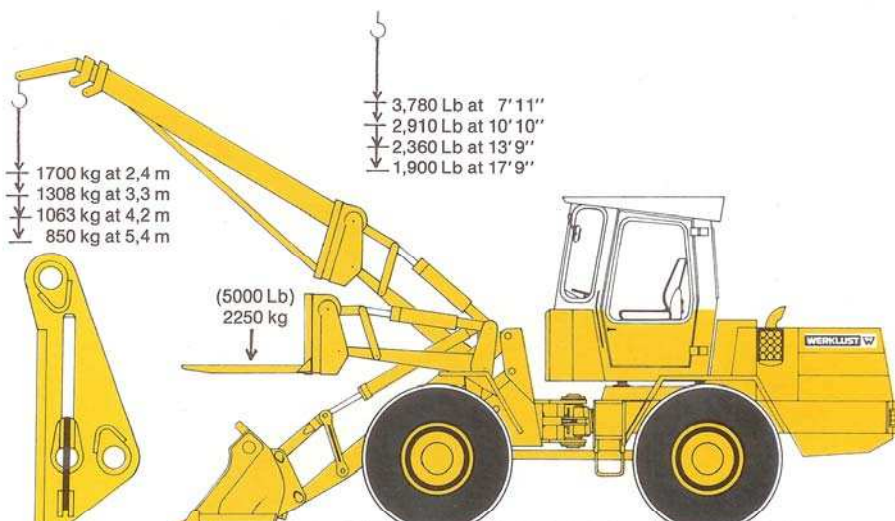

WERKLUST wheelloader WG 16 a pe

The mean features of this - to out-perform designed - Werklust wheel-loader are:

- * Good ground clearance.
- * Good dumping height.
- * Ability to debog by using parallel-kinematic bucket linkage, to free the wheelloader when stuck.
- * Low profile.
- * Low noise.
- * Fingertip control.
- * Good serviceability.
- * Hydrostatic gearbox.
- * A differential lock on the front axle.
- * Low fuel consumption.

FUEL SAVING AND EFFICIENCY

Although a standard diesel engine is used it is possible to cut fuel bills by up to 25%. This is made possible by using a hydraulic system which only supplies hydraulic energy the moment it is required and is called the Load Sensing System. In addition, the loader construction incorporates a rational weight distribution avoiding the use of unnecessary counter-weights. The power saving means the machine works more efficiently with extra speed and acceleration but with greater fuel economy.



SOUND SUPPRESSION

Bearing in mind today's need for quiet machines WERKLUST have arranged components in such a way as to reduce sound levels, i.e. Fuel and Hydraulic tanks are placed between the engine compartment and cab so creating a sound shield. Furthermore, the cab is mounted on vibration dampers so isolating it from the rest of the machine. Where necessary, components, i.e. mudguards, etc., are lined with impact proof material which prevents resonance. In addition, the engine hood is acoustically lined and

the air intakes and outlets have extra baffles. WERKLUST have also designed its own exhaust system. The exhaust Labyrinth is lined inside with high temperature insulation in such a way that both high and low level frequencies are suppressed. All these features combine to produce a sound level of only 78 dBA both inside and outside the cab.



CAB

The simple but rigid design of the cab meets ROPS/FOPS standards (as per SAE J 1040 B/J 231). Resilient mounting of the cab on vibration dampers plus a fully sprung adjustable seat means superb comfort for the operator. Ergonomic mounting of the servo-actuated low effort controls means ease of operation whilst tinted glass in large windows means excellent all round visibility. For even greater comfort the cab can be fitted with an optional WERKLUST specially designed air conditioner.



EASE OF MAINTENANCE

The excellent accessibility on all WERKLUST Wheel Loaders is surpassed on the WG16.



CAB

Spacious, comfortable cab with a full set of instruments and ergonomic located controls.

'sealed bucket pins'

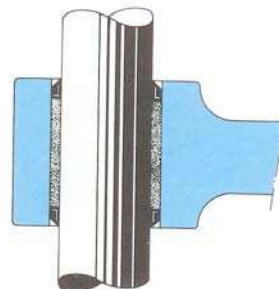

Sealed pins and bushes/bearings

All pins and bushes/bearings on the machine, on loading arm, bucket, center pivot, rear bogey are completely sealed.



The airfilter is designed with precyclones, separating the dust from laden air, under-pressure created by the exhaust, by means of venturi principle. It collects the dust and expels it into the air. This airfilter system increases the active filter times between filter-cleaning cycles considerably, especially where heavy dust pollution is concerned.

erfected, versatile machine



This machine has a swing-hood, activated by gas springs, in order to increase serviceability of the transverse mounted engine. Service and checks can be carried out instantly and efficiently by potting all the hydraulic system reading- and checkpoints to the outside of the machine. Reading is knowing.



Reading is knowing.

Serviceability of the transverse mounted engine.

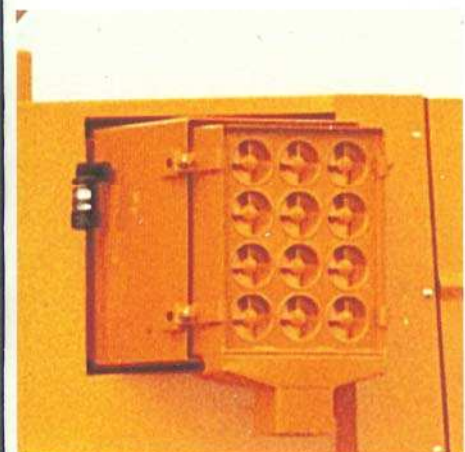

The already excellent dumping height of model WG 16 can be extended considerable by applying a special 'hightip' bucket, reaching a dumping height of 3950 mm. (12'11")



**SPECIFICATIONS WHEELLOADER
WG 16**

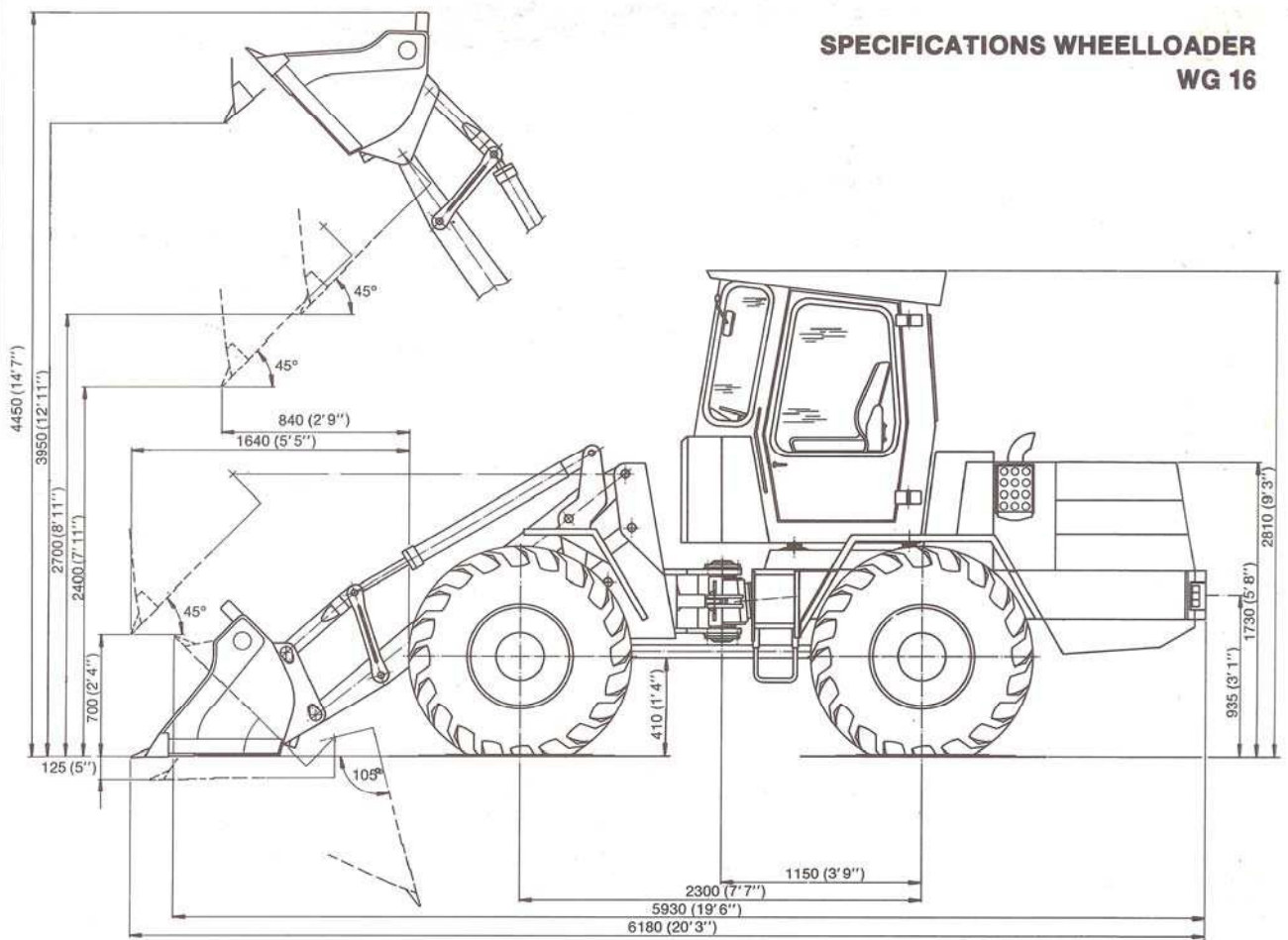

Bucket capacity	1200-1500 ltr (1.6-2 YD ³)
Bucket width	2380 mm (7' 10")
Tipping height (max.)	2700 mm (8' 11")
Tipping height with hightip bucket	3950 mm (12' 11")
Tipping reach at 2400 mm (7' 11") tipping height	840 mm (2' 9")
Payload with standard bucket	2250 kg (5,000 Lb)
Tilting load, straight position	4550 kg (10,110 Lb)
Tilting load, steered angle (40°)	4095 kg (9,100 Lb)
Breakout force	6790 kg (15,100 Lb)
Turning radius	4890 mm (16' 1")
Ground clearance	410 mm (1' 4")
Overall length	6180 mm (20' 3")
Overall width	2240 mm (7' 4")
Overall height	2810 mm (9' 3")
Shipping weight	6800 kg (15,110 Lb)

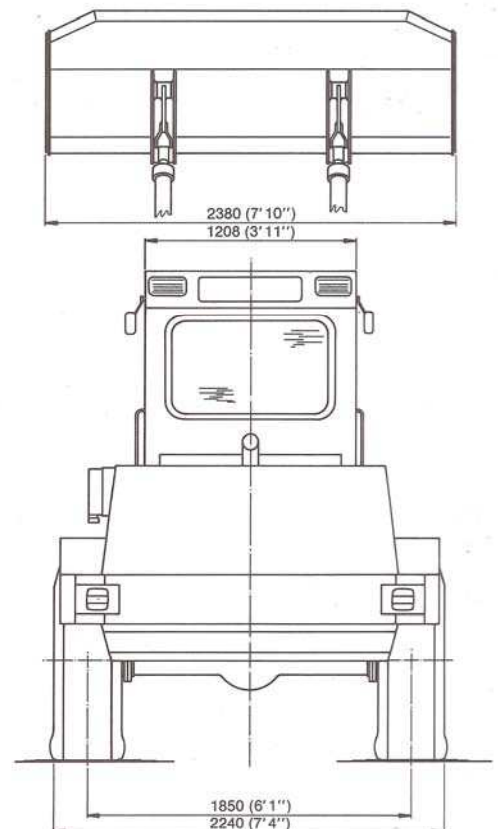



WERKLUST Service and Spare Parts

- For more than 35 years 'WERKLUST' has specialized in the manufacture of wheelloaders to its own, exclusive design. As a result of long experience in producing such efficient machines 'WERKLUST' is in a position to offer top class service and a skilled staff is at user's disposal at all times.
- All 'WERKLUST' components are directly available from stock and 'WERKLUST' has built up a solid reputation to be supplier of spare parts at reasonable prices.



Mainworks
MACHINEFABRIEK WERKLUST B.V.
P.O. Box 159
(Kanaal Zuid 114)
7300 AD - APELDOORN
HOLLAND
Telephone 055-334363 - Telex 36343



Branch
WERKLUST BELGIË P.V.B.A. 3583 - OVERPELT -
BELGIUM
Lod. de Raetlaan 3

WERKLUST 

 and WERKLUST are reg. Trade Marks ©

W 39.8307.2000

Courtesy of Machine.Market